

**NEW**  
Split uKIT

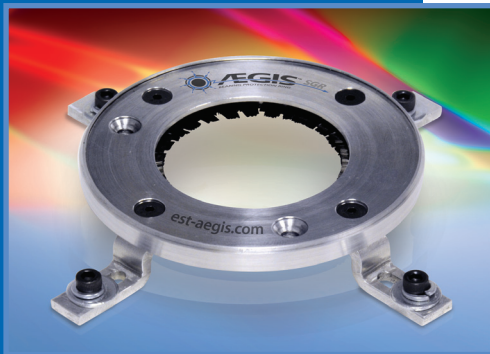

## AEGIS® SGR uKIT Bearing Protection Ring with Universal Mounting Brackets

### AEGIS® SGR - Electrical Bearing Damage Protection™

The new AEGIS® Shaft Grounding Ring Kit with universal mounting brackets allows universal mounting options to fit almost any motor design in the NEMA frames from 56 to 449T. The AEGIS® SGR uKIT includes:

- AEGIS® Bearing Protection Ring designed for the motor's NEMA "u" dimension - shaft diameter
- Solid and Split Ring designs
- Four mounting bracket styles and hardware to adapt the AEGIS® ring to virtually any end bracket
- Screw on or AEGIS® Conductive Epoxy Adhesive mounting capable (Epoxy EP2400 sold separately)
- Fits over slingers, seals or shaft shoulders

#### PROBLEM

Without an AEGIS® Bearing Protection Ring, induced shaft voltages cause destructive bearing currents that can lead to catastrophic "fluting" damage, decrease bearing lubrication life, and premature motor failure.



#### SOLUTION

The AEGIS® Bearing Protection Ring dramatically extends motor service life by safely channeling harmful VFD induced shaft voltages away from the motor's bearings to ground.



Learn more about protecting motors from VFD-induced bearing damage at:

[www.est-aegis.com](http://www.est-aegis.com)

Patented Technology

# TECHNICAL DATA FOR SOLID AND SPLIT RING uKIT DESIGNS

## AEGIS® SGR uKit for NEMA Motors Includes:

- (1) AEGIS® SGR Bearing Protection Ring
- (4) Universal bracket sets
- (4) 5-40 x 3/8" flat head screws
- (4) 6-32 x 3/8" socket head cap screws
- (4) #6 split lock washers
- (4) #6 flat washers
- 5/64" allen wrench
- 7/64" allen wrench

### SOLID RING ONLY Motor with 3 hole bracket pattern

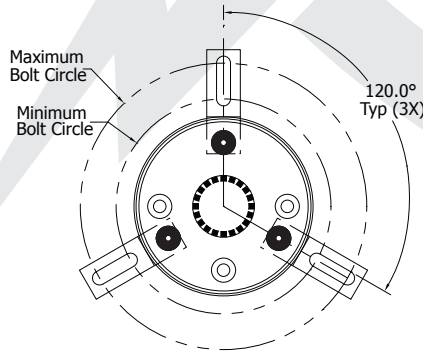

### SOLID AND SPLIT RING Motor with 4 hole bracket pattern

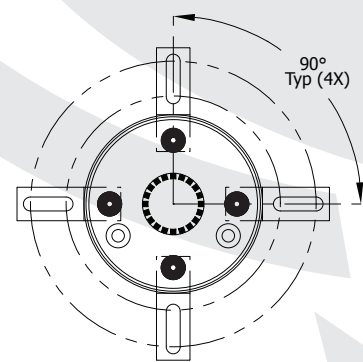

## Tools required for installation:

- #36 drill
- #6-32 tap
- Fine grit emery cloth/sand paper
- CS015 AEGIS® Colloidal Silver Shaft Coating (recommended)



## Tools for Conductive Epoxy Installation

- EP2400 AEGIS® Conductive Epoxy
- Dremel tool for removing paint on motor end bracket
- Heat gun to expedite curing time of conductive epoxy



Shaft	Min Circle	Max Circle
0.625"	2.400"	3.200"
0.875"	2.650"	3.450"
1.125"	2.900"	3.700"
1.375"	3.150"	3.950"
1.625"	3.400"	4.200"
1.875"	3.650"	4.450"
2.125"	3.900"	4.700"
2.375"	4.150"	4.950"
2.875"	4.650"	5.450"
3.375"	5.150"	5.950"
3.625"	5.400"	6.200"
3.875"	5.650"	6.450"
4.375"	6.150"	6.950"
4.875"	6.650"	7.450"

Shaft	Min Circle	Max Circle
0.625"	3.700"	5.375"
0.875"	3.950"	5.625"
1.125"	4.200"	5.875"
1.375"	4.450"	6.125"
1.625"	4.700"	6.375"
1.875"	4.950"	6.625"
2.125"	5.200"	6.875"
2.375"	5.450"	7.125"
2.875"	5.950"	7.625"
3.375"	6.450"	8.125"
3.625"	6.700"	8.375"
3.875"	6.950"	8.625"
4.375"	7.450"	9.125"
4.875"	7.950"	9.625"

Shaft	Min Circle	Max Circle
0.625"	4.575"	5.375"
0.875"	4.825"	5.625"
1.125"	5.075"	5.875"
1.375"	5.325"	6.125"
1.625"	5.575"	6.375"
1.875"	5.825"	6.625"
2.125"	6.075"	6.875"
2.375"	6.325"	7.125"
2.875"	6.825"	7.625"
3.375"	7.325"	8.125"
3.625"	7.575"	8.375"
3.875"	7.825"	8.625"
4.375"	8.325"	9.125"
4.875"	8.825"	9.625"

Mounting bolt circle is the same for 3 or 4 brackets

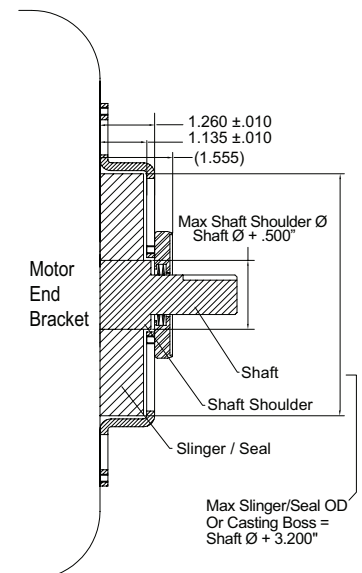
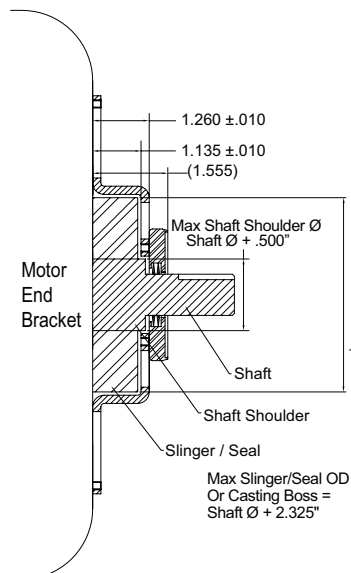
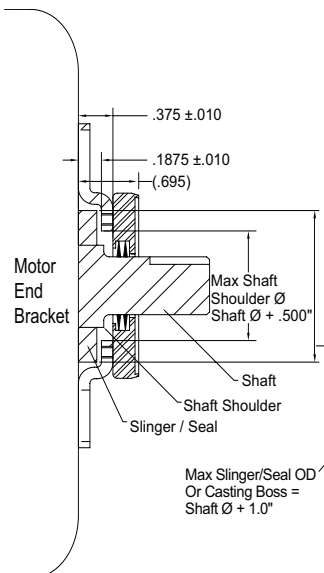

# TECHNICAL DATA FOR SOLID AND SPLIT RING uKIT DESIGNS

## Installation Guide:

1. Shaft must be clean & free of any coatings, paint, or other nonconductive material.

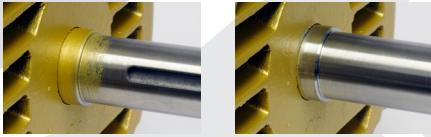

2. AEGIS® SGR should not operate over a keyway. If SGR will operate over a keyway, fill keyway with a fast-curing epoxy putty (such as Devcon epoxy putty) in the area of contact.
3. Select the bracket size based on the clearance needed from the end bracket/slinger/shaft shoulder. For solid ring, choose either a 3 hole or 4 hole bracket pattern, for split ring attach 4 brackets. Attach brackets to the AEGIS® ring using the 5-40 x 3/8" flat head screws.
4. Install the AEGIS® SGR so that the aluminum ring maintains an even clearance around the shaft. Conductive MicroFibers™ must be in contact with the conductive metal surface of the shaft. Mark your bracket locations.
5. To increase the conductivity of the shaft we recommend applying a light

coat of the AEGIS® Colloidal Silver Shaft Coating PN CS015 to the shaft area where the AEGIS® microfibers are in contact with the motor shaft. Apply evenly all around the shaft.

6. Prepare Motor End Bracket for installation with screws:
  - a. Drill (3 or 4) holes using a #36 drill. Avoid drilling into bearing.
  - b. Depth of hole should be 1/4"
  - c. Tap each hole with a #6-32 tap
  - d. Install the uKIT and secure to the motor with the hardware provided. The bolts provide the path to ground. Do not use Loctite© or any other non-conductive material to secure the screws.
7. *Easy Option* Conductive Epoxy Installation (AEGIS® Conductive Epoxy EP2400 sold separately):
  - a. Remove paint on the motor end bracket where the AEGIS® uKIT brackets will be attached. These areas must be clean & free of any coatings, paint, or other nonconductive material.
  - b. Prepare conductive epoxy per package directions
  - c. Apply the epoxy to the Universal brackets
  - d. Install the uKIT. Hold the uKIT in place until epoxy is firmly holding. Allow epoxy to cure for 4 hrs at or above 75°F. For quickest curing time, use a heat gun to heat epoxy for 10 minutes, then allow to cool.



Shaft	Min Circle	Max Circle
0.625"	2.450"	4.325"
0.875"	2.700"	4.575"
1.125"	2.950"	4.825"
1.375"	3.200"	5.075"
1.625"	3.450"	5.325"
1.875"	3.700"	5.575"
2.125"	3.950"	5.825"
2.375"	4.200"	6.075"
2.875"	4.700"	6.575"
3.375"	5.200"	7.075"
3.625"	5.450"	7.325"
3.875"	5.700"	7.575"
4.375"	6.200"	8.075"
4.875"	6.700"	8.575"

Shaft	Min Circle	Max Circle
0.625"	3.700"	5.375"
0.875"	3.950"	5.625"
1.125"	4.200"	5.875"
1.375"	4.450"	6.125"
1.625"	4.700"	6.375"
1.875"	4.950"	6.625"
2.125"	5.200"	6.875"
2.375"	5.450"	7.125"
2.875"	5.950"	7.625"
3.375"	6.450"	8.125"
3.625"	6.700"	8.375"
3.875"	6.950"	8.625"
4.375"	7.450"	9.125"
4.875"	7.950"	9.625"

Shaft	Min Circle	Max Circle
0.625"	4.575"	5.375"
0.875"	4.825"	5.625"
1.125"	5.075"	5.875"
1.375"	5.325"	6.125"
1.625"	5.575"	6.375"
1.875"	5.825"	6.625"
2.125"	6.075"	6.875"
2.375"	6.325"	7.125"
2.875"	6.825"	7.625"
3.375"	7.325"	8.125"
3.625"	7.575"	8.375"
3.875"	7.825"	8.625"
4.375"	8.325"	9.125"
4.875"	8.825"	9.625"

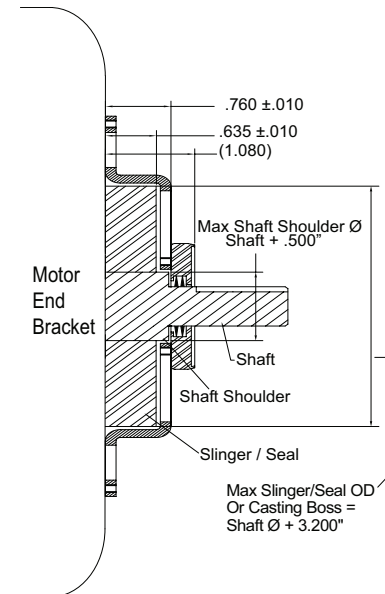
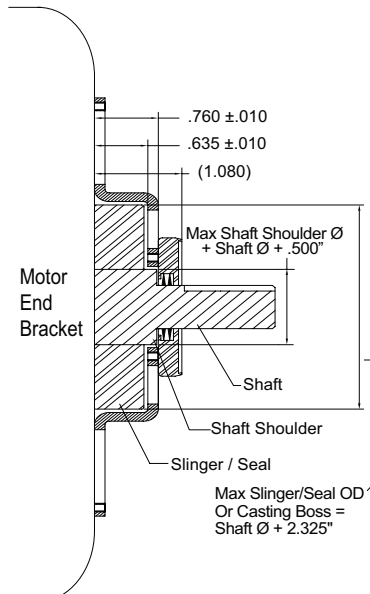
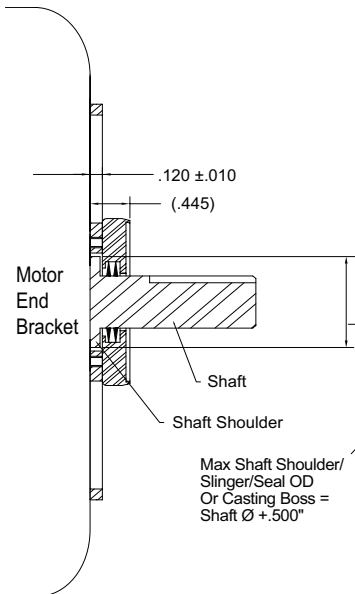



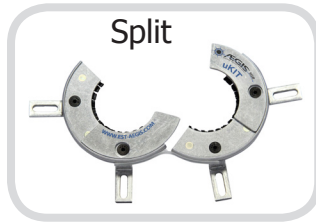

Includes four mounting bracket styles and hardware to adapt the AEGIS® ring to virtually any end bracket.



uKIT Catalog Number Solid Ring	uKIT Catalog Number Split Ring	Motor shaft diameter "u"	NEMA Frame
SGR-0.625-UKIT	SGR-0.625-UKIT-1A4	0.625"	56
SGR-0.875-UKIT	SGR-0.875-UKIT-1A4	0.875"	143T, 145T
SGR-1.125-UKIT	SGR-1.125-UKIT-1A4	1.125"	182T, 184T
SGR-1.375-UKIT	SGR-1.375-UKIT-1A4	1.375"	213T, 215T
SGR-1.625-UKIT	SGR-1.625-UKIT-1A4	1.625"	254T, 256T, 284TS, 286TS
SGR-1.875-UKIT	SGR-1.875-UKIT-1A4	1.875"	284T, 286T, 324TS, 326TS, 364TS, 365TS
SGR-2.125-UKIT	SGR-2.125-UKIT-1A4	2.125"	324T, 326T, 404TS, 405TS
SGR-2.375-UKIT	SGR-2.375-UKIT-1A4	2.375"	364T, 365T, 444TS, 445TS, 447TS, 449TS
SGR-2.875-UKIT	SGR-2.875-UKIT-1A4	2.875"	404T, 405T
SGR-3.375-UKIT	SGR-3.375-UKIT-1A4	3.375"	444T, 445T, 447T, 449T
SGR-3.625-UKIT	SGR-3.625-UKIT-1A4	3.625"	
SGR-3.875-UKIT	SGR-3.875-UKIT-1A4	3.875"	
SGR-4.375-UKIT	SGR-4.375-UKIT-1A4	4.375"	
SGR-4.875-UKIT	SGR-4.875-UKIT-1A4	4.875"	

Optional		
<b>EP2400</b>		AEGIS® Conductive Epoxy 2-3 applications. Used to install AEGIS® SGR without drilling and tapping into the motor end bell.
<b>CS015</b>		AEGIS® Colloidal Silver Shaft Coating 20-25 applications based on a 3" shaft diameter. Used to improve the conductivity of the steel shaft surface. Apply to any VFD driven motor shaft prior to installing the AEGIS® SGR.

**Features and Benefits**

- Protects both motor bearings and the bearings in attached equipment
- Channels harmful currents to ground
- Mounting brackets to fit virtually any motor
- Order the AEGIS® SGR based on the motor "u" dimension, clears slinger or shaft shoulder.
- Improves system reliability; maintenance-free
- Flexible 3 or 4 bracket mounting design