

Dual Modular Safety Shutoff Valve with NEMA 4x Enclosure

DMV-D/604L Series
DMV-DLE/604L Series

DUNGS[®]
Combustion Controls



Two normally closed automatic shutoff valves in one housing; each with the following approvals.

UL Listed

- UL 429
- File # MH 16727

CSA Certified

- ANSI Z21.21
- CSA 6.5
- Marked C/I
- File # 1010989

FM Approved

- Class 7411
- File # 3006982/J.I. IZ 6A0.AF

Commonwealth of Massachusetts Approved Product

- Approval code G1-1107-35
- Gas Safety Shutoff Valve

US & Canadian Models

- DMV-D 702/604, 703/604
- DMV-DLE 702/6, 703/604
- 1 in. NPT - 2 in. NPT
- Rp1 - Rp2

Codes and Standards

This product is intended for installations covered by but not limited to NFPA 86, ANSI Z83.4, ANSI Z83.18, ANSI Z21.13, UL 795, CSD-1 or CSA B149.1 and CSA B149.3.

DUNGS is an ISO 9001 manufacturing facility.

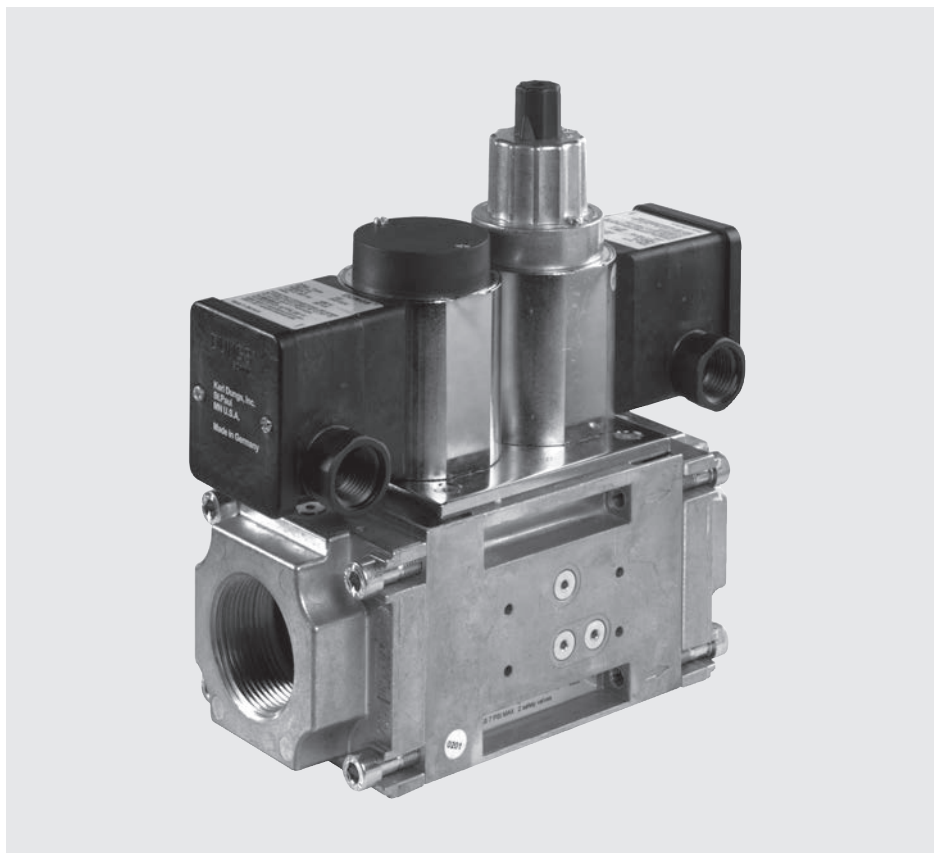

Description

The Dual Modular Valve (DMV) combines two automatic shutoff valves in one compact housing, which can be wired independently or in parallel.

Valve 1 (V1) of the DMV-D and DMV-DLE series is fast opening and fast closing. Valve 2 (V2) of the DMV-D is fast opening, while V2 of the DMV-DLE is slow-opening for smoother light-off. Max. flow adjustment on V2 provides variable main flow on both models.

Internal profiles and compact design optimize flow and provide a low pressure drop. Three body styles reduce inventory.

Directly mounting the following accessories creates a compact valve train without additional piping:

- Pressure regulator
- High and low gas pressure switches
- Valve proving system
- Vent line adapter
- Butterfly control valve

Application

The DMV/604L is recommended for industrial and commercial heating applications that require two safety shutoff valves. The DMV is suitable for dry natural gas, propane, butane, air and other inert gases.

A “dry” gas has a dew point lower than +15 °F and its relative humidity is less than 60 %.

DMV-D.../604L Two normally closed safety shutoff valves in one housing. V1 and V2 are fast opening, fast closing. Adjustable max flow with V2.

DMV-DLE.../604L Two normally closed safety shutoff valves in one housing. V1 fast opening, fast closing. V2 is slow opening, fast closing. Adjustable max flow and Adjustable initial lift with V2.

Specifications

Body sizes	DMV 702	DMV 703
Pipe size / Thread	1" - 2" NPT or Rp	1" - 2" NPT or Rp
Max. operating pressure	7 PSI (500 mbar) UL, FM	5 PSI (360 mbar) CSA
Max. body pressure	15 PSI (1000 mbar)	
Max. close off pressure	7 PSI (500 mbar) UL, FM	5 PSI (360 mbar) CSA
Electrical ratings (+10 % / -15 %)	110 - 120 VAC @ 50 - 60 Hz	
Power ratings	DMV 702: 30 VA	DMV 703: 40 VA
	Ratings shown are total power consumption for each coil. Inrush and full load current have the same VA rating.	
Enclosure rating	NEMA Type 4x	
Electrical connection	Screw terminals with 1/2" NPT conduit connection	
Operating time	100 % duty cycle	
Closing time	< 1 s	
Opening time (to max. flow)	DMV-D.../604 DMV-DLE.../604	V1 & V2 < 1 s V1 < 1 s; V2 Adjustable to approx. 10 to 20 s at 70 °F
Initial lift adjustment	Adjustable on V2	DLE only; 0 to 70 % of total flow; 0 to 25% of stroke
Max. flow adjustment	Adjustable on V2	<10 to 100 % of total flow; <10 to 100% of stroke
Materials in contact with gas	Housing: Aluminium, Steel Sealings on valve seats: NBR-based rubber	
Ambient temperature rating	-20 °F to +150 °F (-30 °C to +65 °C)	
Installation position	Safety shutoff valve from vertically upright to horizontal	
Gas filter (optional)	Replaceable integral gas filter (50 micron) in inlet of DMV or Pre-Mount Filter Block for DMV 702 and 703. (Cannot be used with FRI directly mounted to the DMV)	
Gas strainer (standard)	Installed in the housing upstream V1 (23 mesh)	
Proof of closure switch Factory mounted and calibrated	SPDT switch with indication lamps;	AC max. 10A resistive @ 120 VAC AC max. 8A inductive @ 120 VAC
Position indication (order separately)	CPI 400 with indication lamps and SPDT interlock switch or Visual indicator (VI)	
Test ports / Pressure switch mounting ports	G 1/8 ISO 228 ports available on both sides. Each side has one port upstream V1, one between V1 and V2, one downstream V2, and one on each flange.	
Valve proving system	Requires VPS 504; mounts directly to either side of DMV (Only available in NEMA Type 12 enclosure)	

DMV dual safety shutoff valve modular system

Optional mounting system shown,
other configurations possible

DMV dual safety shutoff valve with upstream FRI pressure regulator

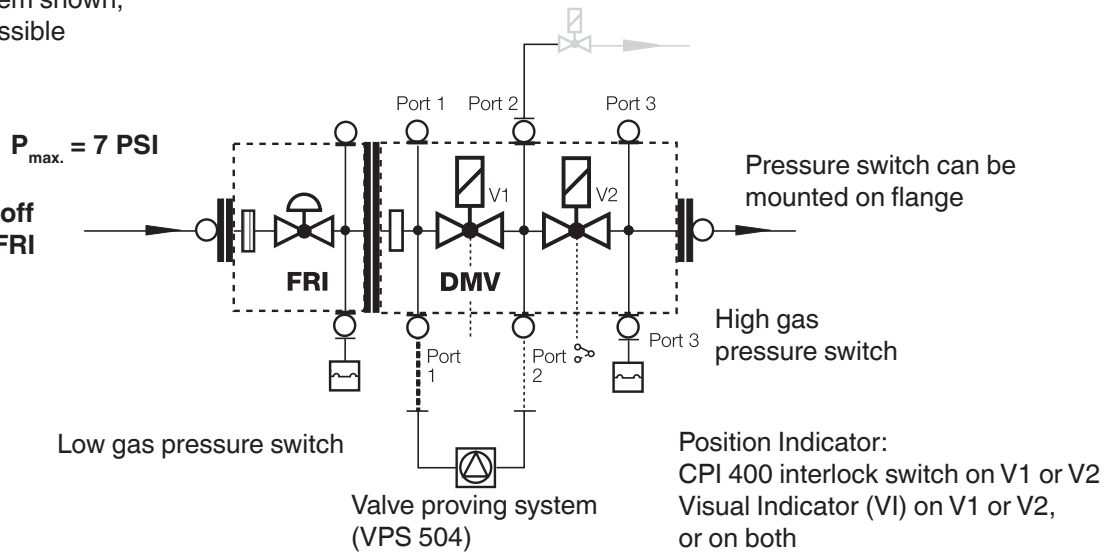

DMV dual safety shutoff valve with downstream FRI pressure regulator

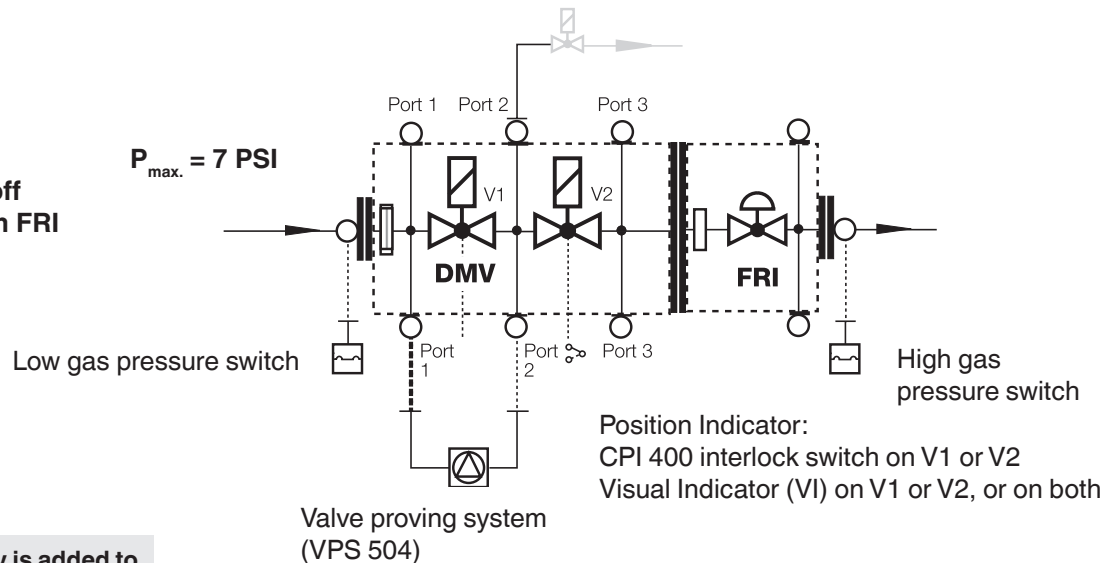

! When an accessory is added to the DMV, it may not be possible to mount other devices.

FRI Gas pressure regulator

Mounting the FRI series gas pressure regulator directly to the DMV dual safety shutoff valve is possible with a mounting kit.

The FRI pressure regulator can be installed upstream or downstream of the DMV dual safety shutoff valve depending on application requirements.

FRI mounting kit for DMV

FRI 710-712/6 to DMV 702/604L + 703/604L
Order No. 219968

Additional Accessories

VPS 504

Valve proving system (approved by some authorities having jurisdiction in lieu of vent valve and "proof of closure" e.g. FM and Swiss Re). NOTE: The VPS is a NEMA type 12 enclosure.

DMK butterfly control valve

Mounts directly downstream of DMV to modulate gas flow. Requires actuator. Use DMA actuator with DMK butterfly valve. NEMA 12 enclosure available.

Integral gas filter (optional)

50 micron gas filter

Pre-Mount Filter (optional)

50 micron gas filter

Adapters

- 1/4" NPT adapter (225047)
- 1/2" NPT Pilot / vent adapter; Check flow requirements. (225043)
- G 1/8" Test nipple with gasket (219008)
- Port 3 Pressure switch mounting adapter (273777)

DMV D(LE) 7xx/604L VLA (with vent line adapter)

Factory installed vent line adapter which integrates a vent line connection with the DMV series.

GAO/GMH/GML A2 pressure switch

Position indication

CPI 400 with indication lamps and SPDT interlock switch, or Visual Indicator (VI).

Dimensions inch (mm)

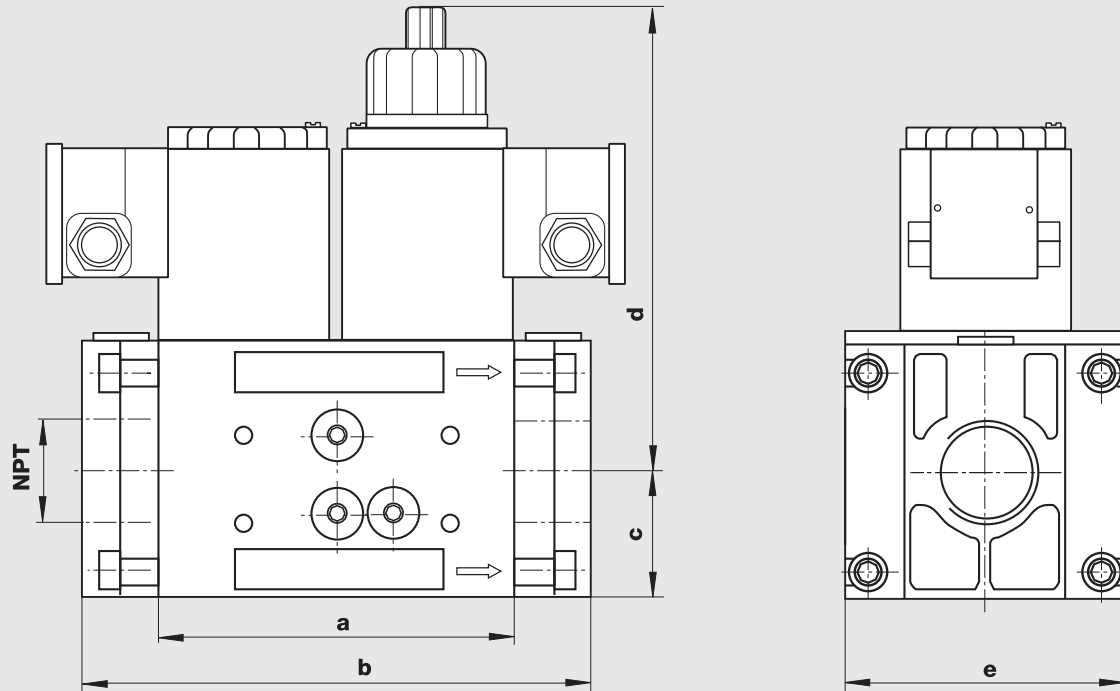

Type	110 - 120 VAC @ 50 - 60 Hz Order No.	Power* [VA]	Dimensions [inch] Dimensions [mm]					Weight [lbs] [kg]
			a	b**	c	d	e	
DMV-D 702/604L	240610	30	4.9 124	6.9 / 7.9 174 / 201	1.8 45	5.9 150	3.9 101	10.1 4,6
DMV-D 703/604L	241436	40	4.9 124	6.9 / 7.9 174 / 201	1.8 45	7.5 190	3.9 101	12.1 5,6
DMV-DLE 702/604L	240805	30	4.9 124	6.9 / 7.9 174 / 201	1.8 45	6.7 197	3.9 101	10.3 4,7
DMV-DLE 703/604L	241435	40	4.9 124	6.9 / 7.9 174 / 201	1.8 45	8.6 218	3.9 101	12.3 5,7

* Inrush current and full load current have the same VA rating.

** DMV 702/703 with 1" or 1 - 1/4" flange; "b" = 6.9" / DMV 702/703 with 1 - 1/2" or 2" flange; "b" = 7.9"

Valve Description	Flange	NPT	Rp
DMV-702/604L & 703/604L	1"	222369	222343
DMV-702/604L & 703/604L	1 1/4"	222370	222370
DMV-702/604L & 703/604L	1 1/2"	222003	221884
DMV-702/604L & 703/604L	2"	221997	221926

Replacement Hydraulic Brake for DLE versions	240458
CPI 400	266968
Visual indicator	266949

Integral gas filter (50 micron) and strainer	P/N
DMV-702/604L	230441
DMV-703/604L	230441

Replacement Coils (120 VAC)	P/N
DMV-702/604L	246515
DMV-703/604L	246516

⚠ Please order flanges, position indicators and gas filters separately

DMV-D(LE).../604L
sectional drawing

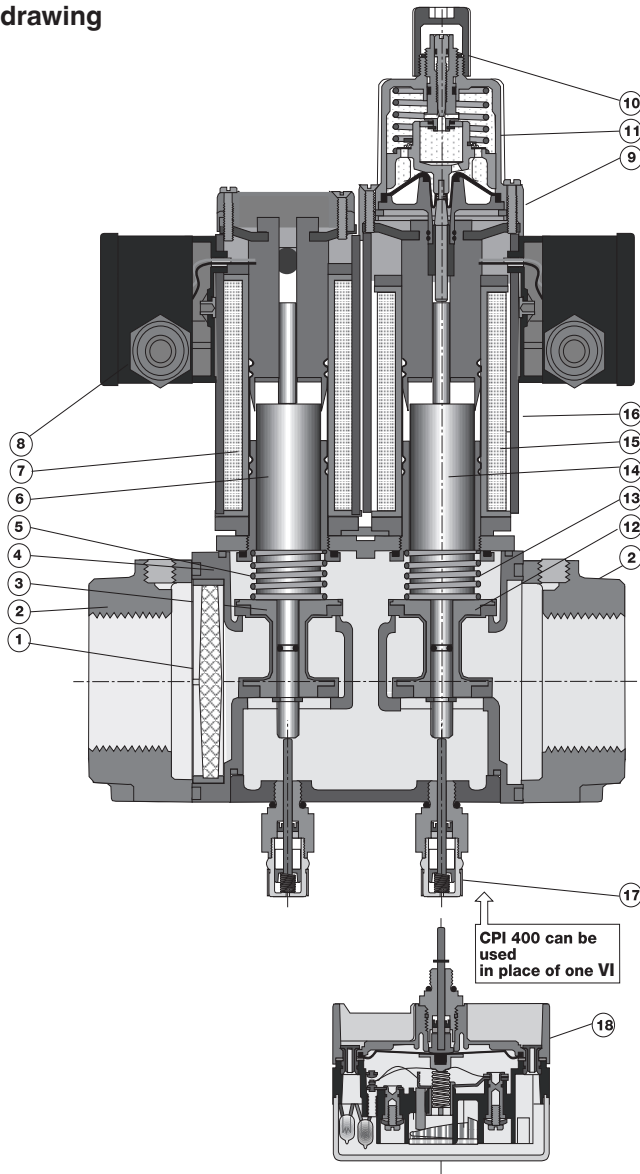

- 1 Strainer
- 2 Flange
- 3 Valve V1
- 4 Housing
- 5 Closing spring V1
- 6 Plunger V1
- 7 Solenoid V1
- 8 Electrical connection
- 9 Max flow adjustment
- 10 Initial lift adjustment (DMV-DLE)
- 11 Hydraulic brake (DMV-DLE)
- 12 Valve V2
- 13 Closing spring V2
- 14 Plunger V2
- 15 Solenoid V2
- 16 Solenoid housing
- 17 Visual indicator (VI)
- 18 CPI 400 interlock switch

Pressure drop for other gases

To determine the pressure drop when using a gas other than natural gas, use the flow formula below and f value located in the table below to determine

the “corrected” flow rate in CFH through the valve for the other gas used. For example, when using propane, divide the volume (CFH) of propane required for the application by the calculated value

f (f = 0.66 for propane). Use this “corrected” flow rate and the flow curve on the next page to determine pressure drop for propane.

Determining equivalent flow through valves using another gas

$$\dot{V}_{\text{gas used}} = \dot{V}_{\text{Natural gas}} \times f$$

$$f = \sqrt{\frac{\text{Density of Natural gas}}{\text{Density of gas used}}}$$

Type of gas	Density [kg/m ³]	s.g.	f
Natural gas	0.81	0.65	1.00
Butane	2.39	1.95	0.58
Propane	1.86	1.50	0.66
Air	1.24	1.00	0.80

**Dual Modular Safety
Shutoff Valve with
NEMA 4x Enclosure**

**DMV-D/604L Series
DMV-DLE/604L Series**



Flow curve

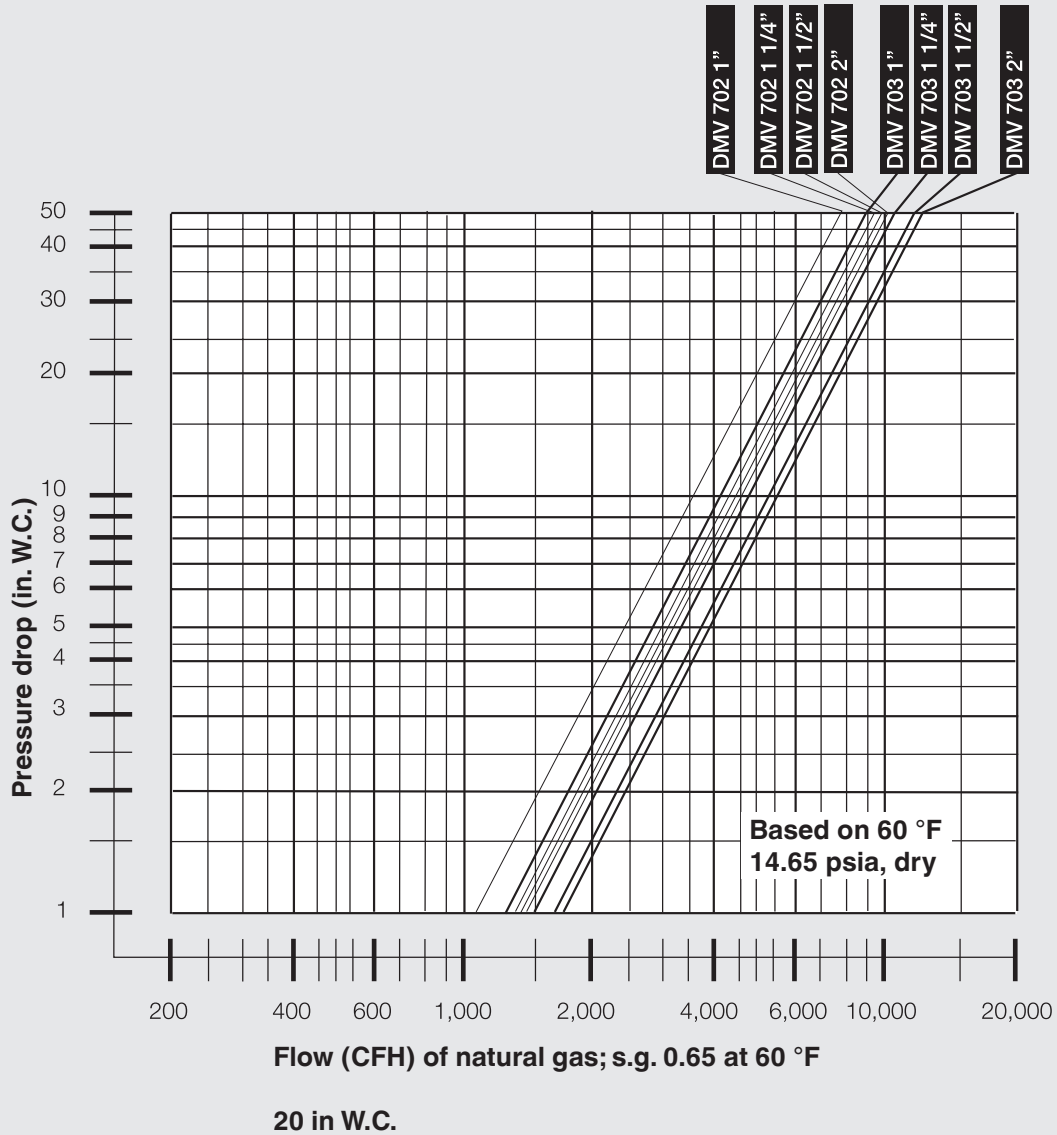

We reserve the right to make any changes in the interest of technical progress.



Karl Dungs, Inc.
3890 Pheasant Ridge Drive NE
Suite 150
Blaine, MN 55449, U.S.A.
Phone 763 582-1700
Fax 763 582-1799
e-mail info@karldungsusa.com
Internet <http://www.dungs.com/usa/>

Karl Dungs GmbH & Co. KG
P.O. Box 12 29
D-73602 Schorndorf, Germany
Phone +49 (0)7181-804-0
Fax +49 (0)7181-804-166
e-mail info@dungs.com
Internet <http://www.dungs.com>