

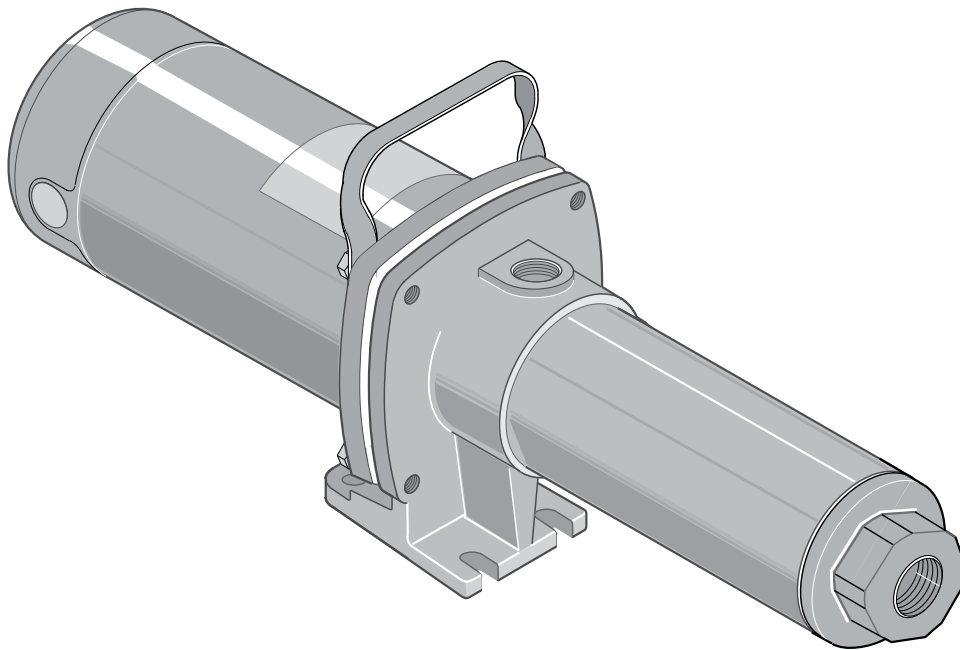

**STA-RITE®**

OWNER'S MANUAL  
**Signature 2000**  
**High Pressure Booster Pump**  
**60 Hz. 1/2 through 3 HP**



## READ AND FOLLOW SAFETY INSTRUCTIONS!

**⚠** This is the safety alert symbol. When you see this symbol on your pump or in this manual, look for one of the following signal words and be alert to the potential for personal injury:

**⚠ DANGER** warns about hazards that **will** cause serious personal injury, death or major property damage if ignored.

**⚠ WARNING** warns about hazards that **can** cause serious personal injury, death or major property damage if ignored.

**⚠ CAUTION** warns about hazards that **will** or **can** cause minor personal injury or property damage if ignored.

The label **NOTICE** indicates special instructions which are important but not related to hazards.

**Carefully read and follow all safety instructions in this manual and on pump.**

Keep safety labels in good condition.  
Replace missing or damaged safety labels.

### California Proposition 65 Warning

**⚠ WARNING** This product and related accessories contain chemicals known to the State of California to cause cancer, birth defects or other reproductive harm.

## ELECTRICAL SAFETY

**⚠ WARNING**



Hazardous voltage. Can shock, burn, or cause death.

Ground pump before connecting to power supply.

**⚠** Some models of pump are supplied with 3-conductor grounding type cord. Connect only to properly grounded, GFCI protected outlet. Do not lift pump by electrical cord.

**⚠** Pump is non-submersible. Keep motor dry at all times. Do not wash motor. Do not immerse. Protect motor from wet weather.

**⚠** If using extension cord, use only UL approved indoor/outdoor, 3-wire, grounding

type cord. Do not allow any part of cord or receptacle ends to sit in water or damp locations.

**⚠** Unplug pump before servicing.

**⚠ CAUTION** Burn Hazard. Do not touch an operating motor. Modern motors can operate at high temperatures. To avoid burns when servicing pump, allow it to cool for 20 minutes after shut-down before handling.

Follow local and/or national plumbing and electrical codes when installing.

**⚠ WARNING** Hazardous Pressure. **DO NOT** run the pump with discharge shutoff, as hose may burst or pump may be damaged due to high temperatures.

## GENERAL SAFETY

To avoid risk of serious bodily injury and property damage, read safety instructions carefully before installing pump.

Do not allow pump or any system component to freeze. To do so may damage system and will void warranty.

**⚠ WARNING** Risk of electric shock. To avoid fatal shocks, proceed as follows if pump needs servicing.

- Disconnect power to pump outlet box before pulling pump cord plug.** After plug is pulled, let pump cool for 20 minutes before attempting to work on it.
- Take extreme care when changing fuses.** To reduce chance of fatal electrical shocks, **DO NOT** stand in water or put your finger in the fuse socket.
- Ground** electrical outlet box.
- Use only Ground Fault Circuit Interrupter (GFCI) protected grounded outlet** for cord plug.

**Never run pump dry.** Running pump dry can damage internal parts, overheat pump (which can cause burns to people handling or servicing pump), and will void warranty.

Do not pump chemicals or corrosive liquids with pump.

**⚠ WARNING** Hazardous Pressure.

- Use high pressure reinforced type discharge hose ONLY.** See parts list for available hose, nozzle and fittings. A high pressure relief valve is recommended.
- DO NOT use garden hose with High Pressure Booster pump.** Garden hose will not stand the discharge pressure produced and will fail.
- High pressure discharge stream is dangerous.** To avoid injury, **DO NOT aim the discharge stream at any person or animal.**
- BE SURE that the pump suction pipe pressure plus the pump discharge pressure does not exceed the pressure rating of hose and fittings.** See Table I for pump discharge pressure ratings.

## INSPECT THE SHIPMENT

The high pressure booster pump has been carefully inspected and packaged to assure safe delivery. Inspect the pump and fittings and report to the carrier any items which are damaged or missing.

**TABLE I - DISCHARGE PRESSURE**

GPM	HP	No. of Stages	Discharge Pressure PSI at Rated Flow	Discharge Pressure PSI at No Flow
7	1/2	9	90	130
7	3/4	12	123	173
7	1	16	162	229
10	1/2	6	74	113
10	3/4	8	97	147
10	1	10	134	188
10	1	11	146	202
10	1-1/2	14	173	206
10	2	16	197	260
20	1	7	75	110
20	1-1/2	9	97	143
20	2	11	123	175
20	3	15	195	250
30	1	5	59	75
30	1-1/2	6	71	91
30	2	7	81	106
30	3	11	129	167

\*For total discharge pressure, add this pressure to suction pipe pressure. For example, an HP7C pump taking suction from a 100 psi water service line will produce  $130 + 100 = 230$  psi total discharge pressure at 0 GPM flow. If suction pressure drops to 50 psi, discharge pressure will drop to 180 psi.

**NOTE:** Model numbers that include an "S" (HPS7C, HPS10D, etc) have a stainless steel suction, discharge assembly, and capscrews. Model numbers ending in "3" (HP7C3, HPS10C3, etc) have 3-phase motors. Model numbers ending in "T" have TEFC motors.

## INSTALLATION

The pump is designed to boost city water pressure or water pressure from a private water system. Use this high pressure stream to wash down milk parlors, barns, garages and driveways, or for fire protection.

The pump is portable with a convenient carrying handle. If an existing pressure water system is to be used as a water supply, it can be connected with available fittings and 3/4" or 1" high pressure hose to the pump inlet. A special heavy duty 3/4" or 1" suction hose with fittings is available as an accessory. If pump is permanently mounted on wall, use a 3/4" or 1" pipe or heavy-duty hose for suction line. 20 GPM models require one-inch discharge hose to reduce friction losses and 30 GPM models require 1-1/4".

**⚠ WARNING** Hazardous pressure. Pump body may explode if pressures exceed rated limits. Maximum inlet pressure is 80 PSI. Maximum discharge pressure is 315 PSI. Warranty is void if these pressure limits are exceeded.

### HIGH PRESSURE BOOSTER PUMP INSTALLATION INSTRUCTIONS

These instructions cover high pressure booster pump installations as shown below:

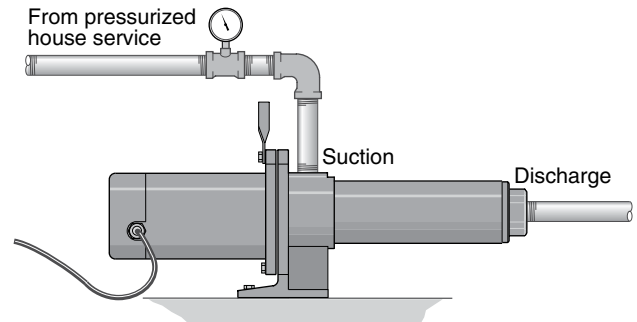

**Figure 1 – Connection to house service.**

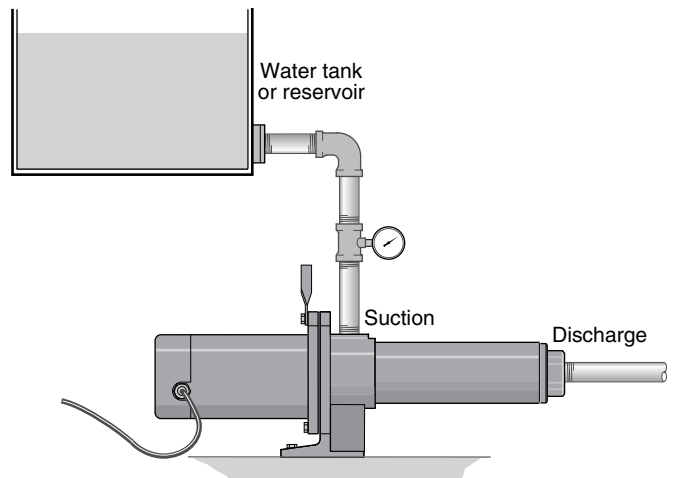

**Figure 2 – Connection to water reservoir.**

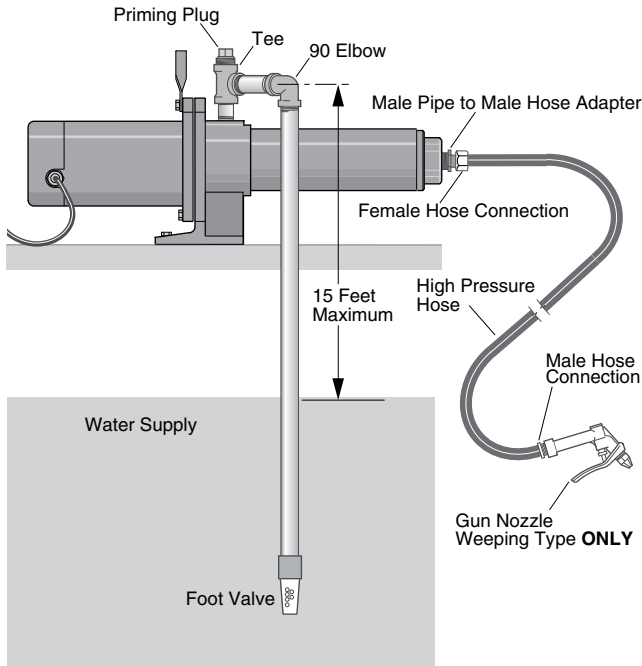

**Figure 3 – Cistern or shallow well installation.**

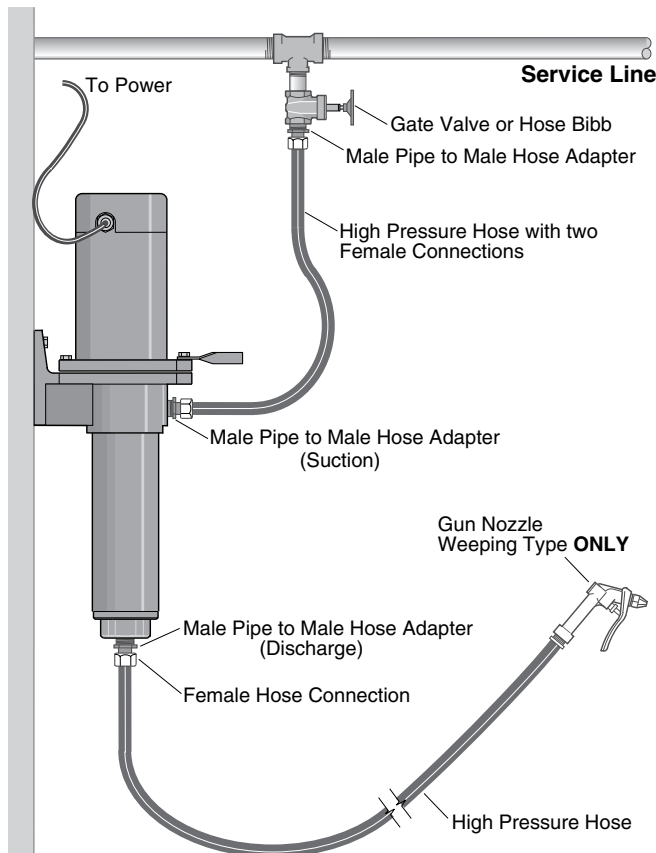

1209 0894

**Figure 4 – Wall mounted to pressurized service line.**

To reduce friction losses to a minimum, inlet (suction) line should be **short** and have as few elbows as possible.

Size the inlet according to the chart below:

Ave. GPM	Threaded Inlet Size	Recommended Inlet Line Size	Recommended Discharge Line Size
7	3/4" NPT	1"	1"
10	3/4" NPT	1"	1"
20	1" NPT	1-1/4"	1-1/4"
30	1-1/4" NPT	1-1/2"	1-1/2"

An inlet strainer will prevent suspended debris from clogging pump.

The internal running surfaces of the pump and seals require water lubrication for good, consistent operation. **Allowing pump to run dry will severely damage pump and seals.**

Install a pressure gauge in pump inlet line. Keep at least two pounds per square inch pressure (2 PSI) in inlet line whenever pump is operating. If this is not possible, consult customer service representative.

## LUBRICATION

It is not necessary to lubricate pump or motor. The motor is equipped with sealed ball bearings, lubricated for the life of the bearing. The mechanical shaft seal in the pump is self-lubricating and requires no adjustment. Disassemble pump to replace seal (See "Maintenance", Pages 8 to 9).

## OPERATION

**NOTICE:** Observe the following precautions when operating the pump:

1. **Keep the motor dry! Do not** direct stream from pump discharge onto the motor!
2. **⚠️ WARNING Hazardous pressure. Do not** run the pump with discharge shutoff, as hose may burst or pump may be damaged due to high temperatures.
3. **Do not** use a standard trigger gun with this pump. Use only trigger guns with an automatic weeping feature. These are available as accessories and are provided with three nozzles. The smallest nozzle restricts the flow, allowing use of a smaller water source. The two larger nozzles are used if the water source will supply the pump's full capacity.
4. **Do not** run pump dry; to do so may damage the seal.
5. To avoid internal damage to pump, **Do not** operate with water temperature above 175 degrees F.

**⚠ Disconnect power before working on pump, motor, pressure switch, or wiring.**

## Single Phase, ODP Motor

### MOTOR SWITCH SETTINGS

Dual-voltage motors (motors that can operate at either 115 or 230 volts), are set at the factory to 230 volts. Do not change motor voltage setting if line voltage is 230 volts, or if you have a single voltage motor.\*

**NOTICE:** Never wire a 115 volt motor to a 230 volt line.

### REMOVE MOTOR END COVER

If you have a dual-voltage motor, and will connect it to 115 volts, follow the procedure below.

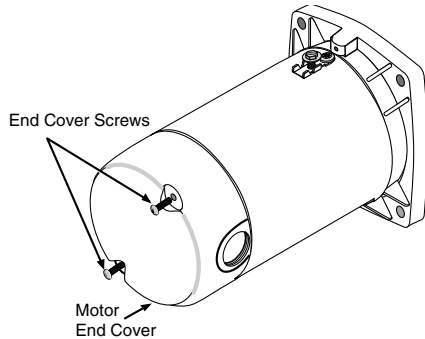
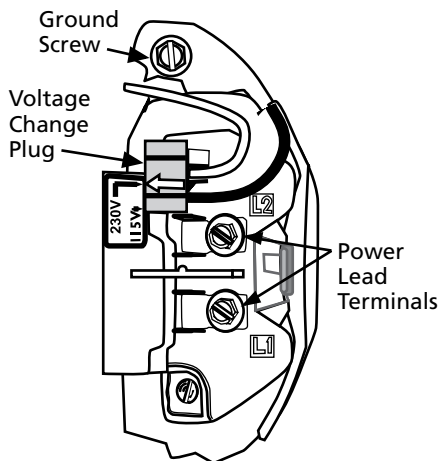

**Figure 5 – Removing Motor End Cover**

You will need to remove the motor end cover to change the voltage setting.

Your motor terminal board (located under the motor end cover) should look like one of the following.

### PLUG TYPE VOLTAGE SELECTOR



**Figure 6 – Voltage set to 230 volts, Plug Type**

To change to 115 volts:

1. Make sure power is off.
2. Pull the plug straight up.

*\*Models with power cords are pre-wired for 115 volts. This includes models HP7D-02 and HP7C-02.*

3. Move and attach the plug at the 115 volt position. The plug will now cover 2 metal tabs. The arrow on the plug will point to 115V.
  4. Attach the power lead wires to the power lead terminals. Make sure the wires are secure.
  5. Attach the ground wire to the green ground screw
  6. Reinstall the Motor end cover
- Go to Wiring Connections, page 6.

### DIAL TYPE VOLTAGE SELECTOR

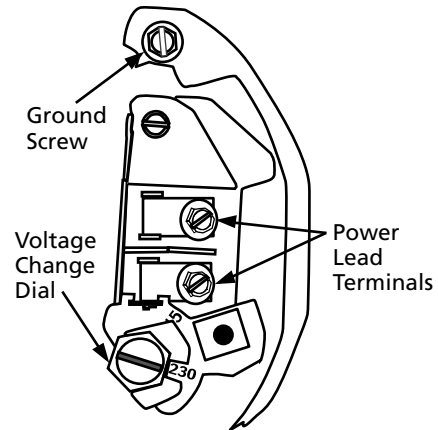







**Figure 7 – Voltage set to 230 volts, Dial Type**

To change to 115 volts:

1. Make sure power is off.
  2. Turn the dial counter-clockwise until 115 shows in the dial window.
  3. Attach the power lead wires to the power lead terminals. Make sure the wires are secure.
  4. Attach the ground wire to the green ground screw
  5. Reinstall the Motor end cover
- Go to Wiring Connections, page 6.

## ELECTRICAL

-  **Ground motor before connecting to electrical power supply.**
-  **Failure to ground motor can cause severe or fatal electrical shock hazard.**
-  **Explosion hazard. Do not ground to a gas supply line.**
-  **To avoid dangerous or fatal electrical shock, turn OFF power to motor before working on electrical connections.**
-  **Supply voltage must be within  $\pm 10\%$  of nameplate voltage. Incorrect voltage can cause fire or serious damage to motor and voids warranty. If in doubt consult a licensed electrician.**
-  **Use wire size specified in Wiring Chart (Table II, Page 7). If possible, connect pump to a separate branch circuit with no other appliances on it.**
-  **Wire motor according to diagram on motor nameplate. If nameplate diagram differs from diagrams above, follow nameplate diagram.**

**For All 3-phase and TEFC Motors:** Follow the wiring diagram on the motor junction box or on the motor nameplate.

## WIRING CONNECTIONS

1. Install, ground, wire and maintain this pump in compliance with the National Electrical Code (NEC) or the Canadian Electrical Code (CEC) and with all local codes and ordinances that apply. Consult your local building inspector for local information.

2. Make sure that the voltage, frequency and phase (single phase or three phase) of the power supply agree with that stamped on the motor nameplate. If in doubt, check with the power company.
3. Some models are equipped with three phase motors. Three phase motors require magnetic starters and can run in either direction, depending on how they are connected to the power supply.

**NOTICE:** Dual voltage motors without cords are factory wired for 230 volts. If necessary, reconnect the motor for 115 volts, as shown. All cord connected motors are wired for 115 volts (See Page 5). Do not alter the wiring in single voltage motors.

Install, ground, wire, and maintain your pump in compliance with the National Electrical Code (NEC) or the Canadian Electrical Code (CEC), as applicable, and with all local codes and ordinances that apply. Consult your local building inspector for code information.

**NOTICE:** Clamp the power cable to prevent strain on the terminal screws.

**NOTICE: Your Motor Terminal Board (under the motor end cover) looks like one of those shown above. Do not change motor wiring if line voltage is 230 volts. Connect power supply as shown for your supply voltage.**

**NOTICE:** Some models are equipped with three phase motors. Three phase motors require magnetic starters and can run in either direction, depending on how they are connected to the power supply.

**To Check For Proper Rotation – 3 Phase Motors**

**▲ WARNING Risk of electrical shock.**

1. Be sure power is disconnected to motor when working on electrical connections.
2. Remove the motor end cover, exposing motor shaft. Momentarily start pump. If hookup is correct, the shaft will rotate clockwise.
3. If rotation is not clockwise, reverse any two leads to the starter. The rotation will now be correct.

**GROUNDING THE MOTOR**

Ground the pump permanently using a wire of size and type specified by local or National Electrical Code.

**Models (HP7C and HP7D Series Only) with factory installed cord and plug:**

**▲ WARNING Risk of electric shock.** This equipment is only for use on 115V and is equipped with an approved 3-conductor cord and 3-prong, grounding type plug. To reduce the risk of electric shock, be certain that it is connected to a properly grounded, grounding type receptacle. Do not modify or remove plug. Make sure pump circuit meets National Electrical Code. To avoid dangerous electrical shock hazard, keep cord dry at all times.

**Models without cord and plug:**

1. Connect ground wire first. Connect the ground first, then to green grounding terminal provided under motor canopy (see Figures 6 and 7) identified as GRD. Make ground connection to this terminal. **Do not** connect motor to electrical power supply until unit is permanently grounded; otherwise serious or fatal electrical shock hazard may be caused.
2. For best ground connection, connect to a grounded lead in the service panel or to a metal underground water pipe or well casing at least 10 ft. long. If plastic pipe or insulated fittings are used, run ground wire directly to the metal well casing or use ground electrode furnished by the power company.

**TABLE II - RECOMMENDED FUSING AND WIRING**

Motor Type	Motor H.P.	Volts/Phase	Max. Load Amps	Branch Fuse Rating Amps	Wire Length		
					0'-100'	101-200'	201-300'
					AWG Wire Size		
ODP	1/2	115/230/1	12.4/ 6.2	20/15	12/14	10/14	8/14
ODP	1/2	230/460/3	3.1/1.55	15/15	14/14	14/14	14/14
ODP	3/4	115/230/1	14.8/7.4	20/15	12/14	8/14	6/14
ODP	3/4	230/460/3	3.6/1.8	15/15	14/14	14/14	14/14
ODP	1	115/230/1	19.2/9.6	25/15	10/14	8/14	6/12
ODP	1	230/460/3	4.7/2.35	15/15	14/14	14/14	14/14
ODP	1-1/2	115/230/1	24/12	30/15	10/14	6/12	6/12
ODP	1-1/2	230/1	12.0	15	14	14	12
ODP	1-1/2	230/460/3	6.8/3.4	15/15	14/14	14/14	14/14
ODP	2	115/230/1	26/13	35/20	8/12	6/12	4/10
ODP	2	230/1	10.4	15	14	14	14
ODP	2	230/460/3	6.0/3.0	15/15	14/14	14/14	14/14
ODP	3	208-230/1	15.0	20	12	12	10
ODP	3	200-230/460/3	11.5/5.8	15/15	14/14	14/14	12/14
TEFC	1	115/230/1	18/9	25/15	10/14	8/14	8/12
TEFC	1	208-230/460/3	4.8/2.4	15/15	14/14	14/14	14/14
TEFC	1-1/2	230/1	10.4	15	14	14	12
TEFC	1-1/2	208-230/460/3	6.0/3.0	15/15	14/14	14/14	14/14
TEFC	2	230/1	11.7	15	14	10	8
TEFC	2	208-230/460/3	7.0/3.5	15/15	14/14	14/14	14/14
TEFC	3	230/1					
TEFC	3	208-230/460/3	7.0/3.5	15/15	14/14	14/14	14/14

## MAINTENANCE

### Pump Disassembly

**⚠ WARNING Hazardous voltage.** Can shock, burn or cause death. Disconnect power before servicing.

Tools required:

1. 7/16" open end wrench (2 required).
2. Flat blade screwdriver with insulated handle.
3. Work bench with vise recommended.
4. Pliers or similar tool.
5. Pipe wrench.

### Impeller Stack Changeout (See Figure 8)

Remove pump from service and mount vertically in vise (if available) motor side down. Hold at center of motor. It may be desirable to wrap motor with a shop rag to protect outside surface.

Proceed as follows:

1. Attach pipe wrench to flats on discharge connection and turn clockwise to remove (left hand threads).
2. Remove screws holding motor canopy and remove canopy. Pull straight off as shown. Leave switch wires attached (if present).

**⚠ WARNING Capacitor voltage may be hazardous.** To discharge capacitor, hold insulated handle screwdriver **by the handle** and short capacitor terminals together. Do not touch metal screwdriver blade or capacitor terminals.

3. Unscrew the overload and move it aside. Do not disconnect wires. Slide 7/16" open end wrench in behind spring loaded centrifugal switch as shown. Place on motor shaft flats to hold shaft stationary.
4. With one 7/16" wrench in place on motor shaft, place second wrench on shaft hex at pump end and unscrew impeller stack by turning counter-clockwise.
5. Once loose from motor shaft, hold shaft by snap ring using a pliers or similar tool, and pull stack from shell. You may have to apply a back and forth motion to break stack loose from shell.

To assemble with replacement impeller stack, keep pump in the vertical position, motor down, and reverse instructions 1 through 5.

Assembly hints:

- A. Apply a soapy water solution to suction and discharge O-Rings to ease seating of shell.
- B. Make sure mechanical shaft seal spring is in proper position on motor shaft.
- C. On three-phase models, apply Loctite No. 271 to motor shaft threads before reinstalling stack.

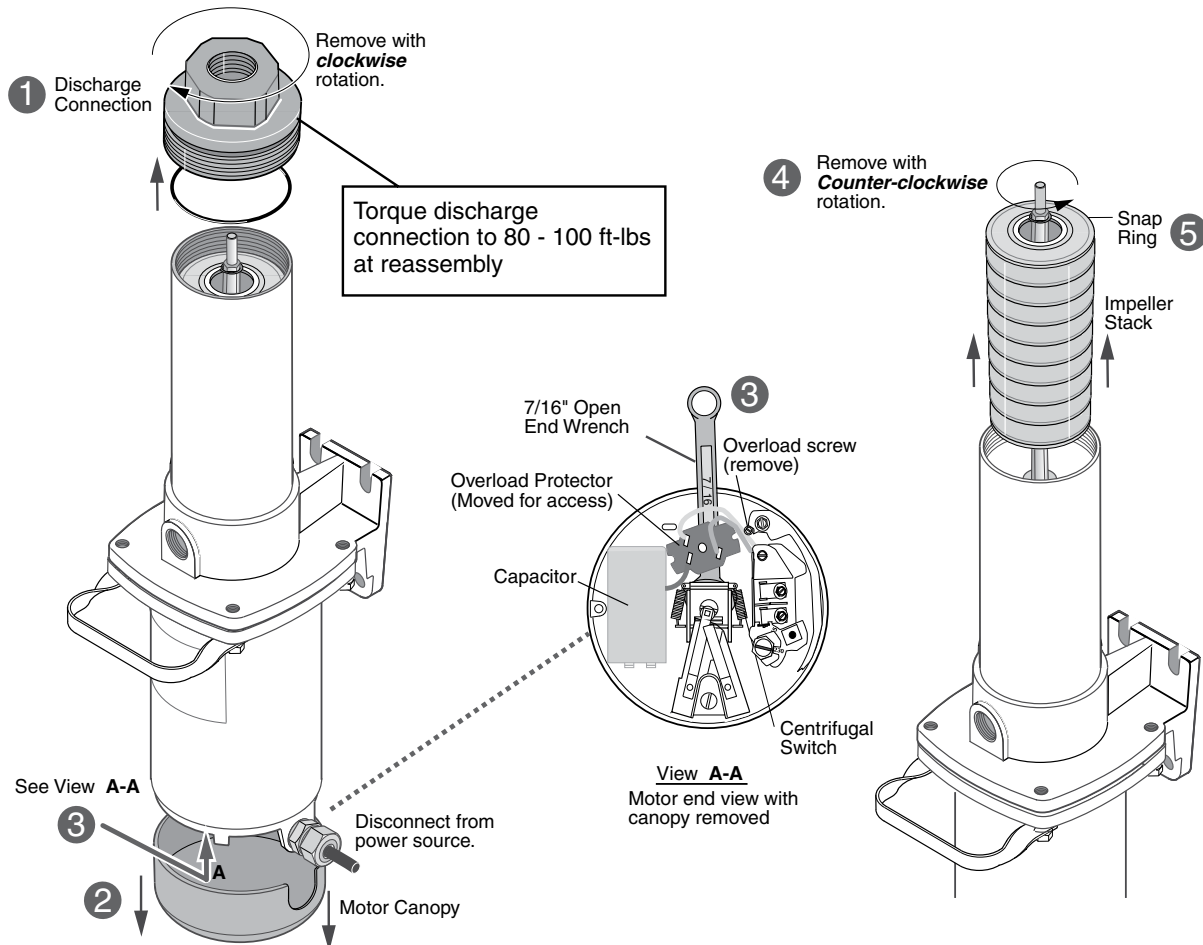

Figure 8 – Impeller stack changeout.



## Mechanical Seal Changeout

(Refer to Figures 8 and 9)

This procedure is best completed with the pump held in a vertical position, motor down.

First complete “**Disassembly**” instructions 1 through 5 under “**Impeller Stack Changeout.**” (See Figure 8).

6. Remove 4 capscrews holding pump body to motor. Pump handle will come off with top capscrews.
7. Unscrew pump shell from pump body, turning clockwise (left hand threads).
8. Remove mechanical shaft seal spring and rotating half from motor shaft. Use care not to scratch motor shaft when removing rotating half.
9. Remove pump body from motor and place on flat surface, face down. Again, use care not to scratch motor shaft.
10. Use a screwdriver to push ceramic seat out from seal cavity as shown.
11. Installation of ceramic seat:
  - A. Turn pump body over so seal cavity is up; clean cavity thoroughly.
  - B. Clean polished surface of ceramic seat with a clean cloth.
  - C. Lubricate outside rubber surface of seat with soapy water. Place cardboard washer over

polished face of seat and press into seal cavity using a 3/4” socket or a piece of 3/4” standard pipe.

- D. Be sure polished surface of seat is free of dirt and has not been damaged by insertion. Re-move excess soapy water. Dispose of cardboard washer.

### 12. Installation of rotating half and spring:

- A. Reinstall pump body on motor using extreme caution not to hit ceramic portion of seal on motor shaft. Reattach pump body to motor using capscrews. Be sure to reinstall pump handle at this time.
- B. Inspect shaft to make sure that it is clean.
- C. Clean face of rotating half of seal with a clean cloth.
- D. Lubricate inside diameter of rotating half with soapy water and slide onto motor shaft (sealing face first).
- E. Place spring over motor shaft so it rests on rotating half.

### 13. To complete reassembly from this point, reverse instructions 1 through 5 under “**Impeller Stack Changeout.**”

**NOTICE:** Lubricate suction and discharge O-Rings with soapy water for easier installation of shell.

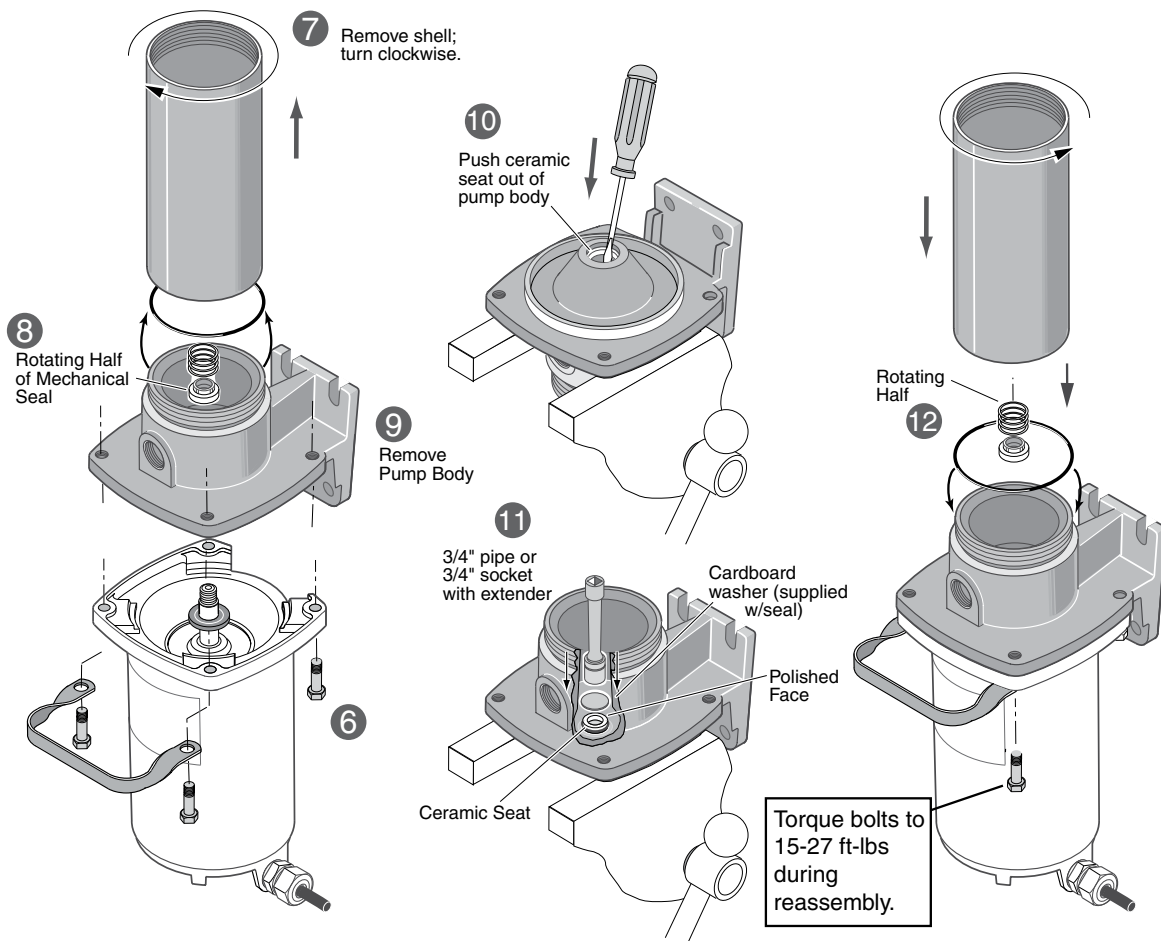
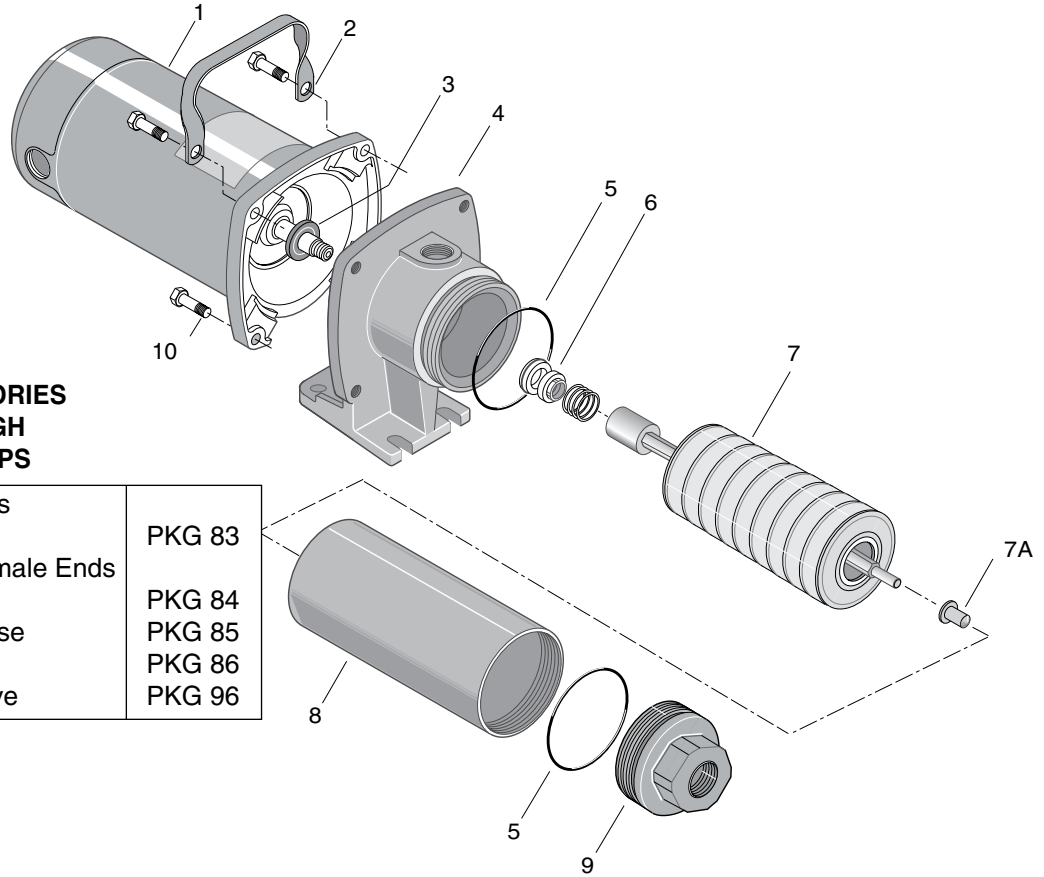

Figure 9 – Mechanical seal changeout.



**THE FOLLOWING ACCESSORIES  
MAY BE ORDERED FOR HIGH  
PRESSURE BOOSTER PUMPS**

Hose 6'-3/4" w/Female Ends (150 PSI Rating)	PKG 83
Hose 25'-3/4" w/Male & Female Ends (150 PSI Rating)	PKG 84
Adapter 3/4" NPT x 3/4" Hose	PKG 85
Nozzle - High Pressure	PKG 86
Suction Vacuum Relief Valve	PKG 96

**Figure 9 – Exploded view.**

1206 0605 NCBSW/NB

## REPAIR PARTS LIST

Key No.	Description	Qty.	HP7C-02 HP7C3-02 HP10C-02 HP10C3-02 1/2 HP	HP7D-02 HP7D3-02 HP10D-02 HP10D3-02 3/4 HP	HP7E-02 HP7E3-02 HP10E-02 HP10E3-02 HP10E311-02 1 HP	HP10F-02 HP10F3-02 1-1/2 HP	SHP10G3-02 HP10G-02 HP10G3-02 2 HP
1	Motor - 115/230 Volt, 1 Phase	1	J218-590PKG	J218-596PKG	J218-601PKG	J218-883APKG	J218-628APKG
1	Motor - 230/460 Volt, 3 Phase	1	AP100CH	AP100DL2	AP100EH	AP100FH	AP100GH
2	Handle (†)	1	C54-21	C54-21	C54-21	—	—
3	Water Slinger	1	17351-0009	17351-0009	17351-0009	17351-0009	17351-0009
4	Pump Body	1	C2-85	C2-85	C2-85	C2-85	C2-85
5	O-Ring	2	U9-430	U9-430	U9-430	U9-430	U9-430
6	Shaft Seal Assembly	1	U109-118	U109-118	U109-118	U109-118	U109-118
7	Pump Stack (7 GPM Pump)	1	P325-422	P325-423	P325-424	—	—
7	Pump Stack (10 GPM Pump)††	1	P325-425	P325-426	P325-439	P325-428	P325-429
7A	Nylatron Bearing (included with Key No. 9)	1	W31112	W31112	W31112	W31112	W31112
8	Pump Shell (7 GPM Pump)	1	P56-430SSL	P56-431SSL	P56-432SSL	—	—
8	Pump Shell (10 GPM Pump)†††	1	P56-460SSL	P56-461SSL	P56-469SSL	P56-452SSL	P56-432SSL
9	Discharge Assembly	1	C152-3	C152-3	C152-3	C152-3	C152-4
10	Capscrew - 3/8 x 16 x 1-1/2"	4	U30-982ZP	U30-982ZP	U30-982ZP	U30-982ZP	U30-982ZP
#	Cord Connector**	1	U71-7	U71-7	—	—	—
#	Cord**	1	U17-402	U17-1238	—	—	—

# Not Illustrated.

\*\* Included with Model Numbers HP7C-01 and the HP7D Series Model Numbers.

† Handle comes with HP7 series and HP10E series.

†† Model HP10E311-02 uses Part Number P325-362.

††† Model HP10E311-02 uses Part Number P56-404SSL.

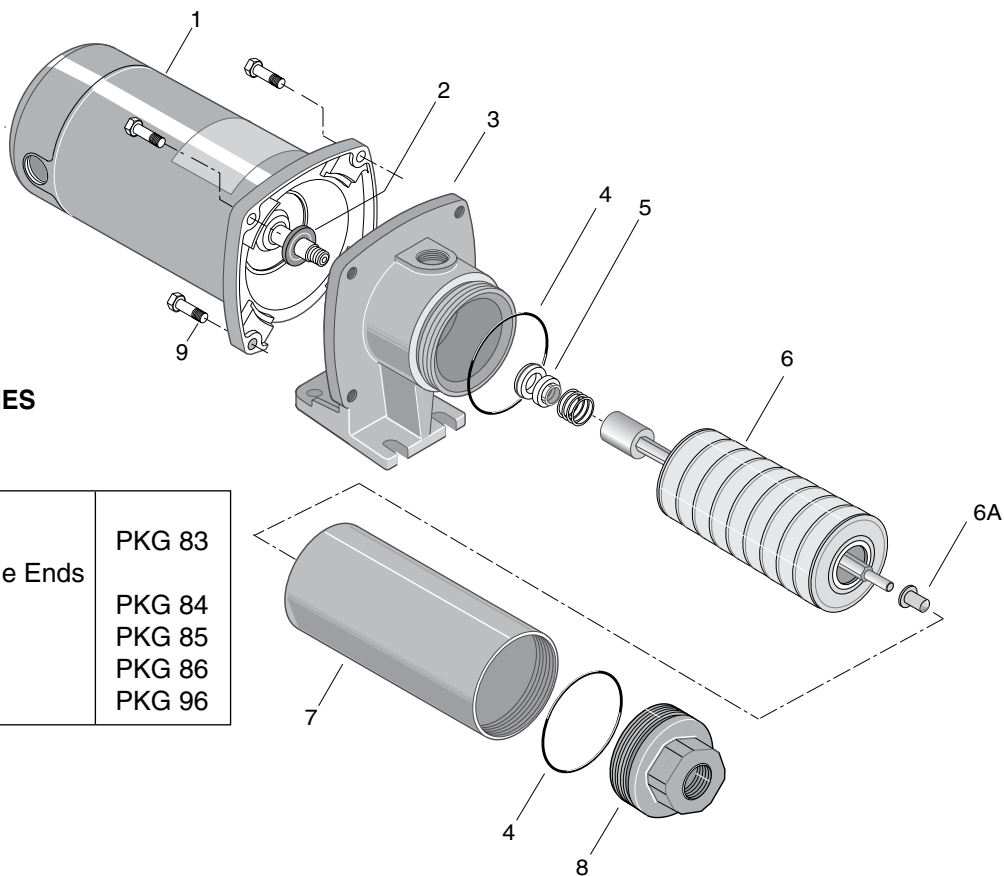

**THE FOLLOWING ACCESSORIES  
MAY BE ORDERED FOR HIGH  
PRESSURE BOOSTER PUMPS**

Hose 6'-3/4" w/Female Ends (150 PSI Rating)	PKG 83
Hose 25'-3/4" w/Male & Female Ends (150 PSI Rating)	PKG 84
Adapter 3/4" NPT x 3/4" Hose	PKG 85
Nozzle - High Pressure	PKG 86
Suction Vacuum Relief Valve	PKG 96

**Figure 10 – Exploded view.**

1206 0605 NHW/NB

**REPAIR PARTS LIST**

Key No.	Description	Qty.	HPS7C-01 HPS7C3-01 HPS10C-01 HPS10C3-01 1/2 HP	HPS7D-01 HPS7D3-01 HPS10D-01 HPS10D3-01 3/4 HP	HPS7E-01 HPS7E3-01 HPS10E-01 HPS10E3-01 1HP	HPS10F-01 HPS10F3-01 1-1/2 HP	HPS10G-01 HPS10G3-01 2 HP
1	Motor - 115/230 Volt, 1 Phase	1	J218-590PKG	J218-596PKG	J218-601PKG	J218-883APKG	J218-628APKG
1	Motor - 230/460, 3 Phase	1	AP100CH	AP100DL2	AP100EH	AP100FH	AP100GH
2	Water Slinger	1	17351-0009	17351-0009	17351-0009	17351-0009	17351-0009
3	Pump Body	1	C2-86SS	C2-86SS	C2-86SS	C2-86SS	C2-86SS
4	O-Ring	2	U9-430	U9-430	U9-430	U9-430	U9-430
5	Shaft Seal Assembly	1	U109-118	U109-118	U109-118	U109-118	U109-118
6	Pump Stack (7 GPM)	1	P325-422R	P325-423R	P325-424R	-	-
6	Pump Stack (10 GPM)	1	P325-425R	P325-426R	P325-439R	P325-428R	P325-429R
6A	Nylatron Bearing (included with Key No. 9)	1	W31112	W31112	W31112	W31112	W31112
7	Pump Shell (7GPM)	1	P56-430SSL	P56-431SSL	P56-432SSL	-	-
7	Pump Shell (10GPM)	1	P56-460SSL	P56-461SSL	P56-469SSL	P56-452SSL	P56-432SSL
8	Discharge Assembly	1	C152-4	C152-4	C152-4	C152-4	C152-4
9	Capscrew 3/8 x 16 x 1-1/2", S.S.	4	S25983	S25983	S25983	S25983	S25983

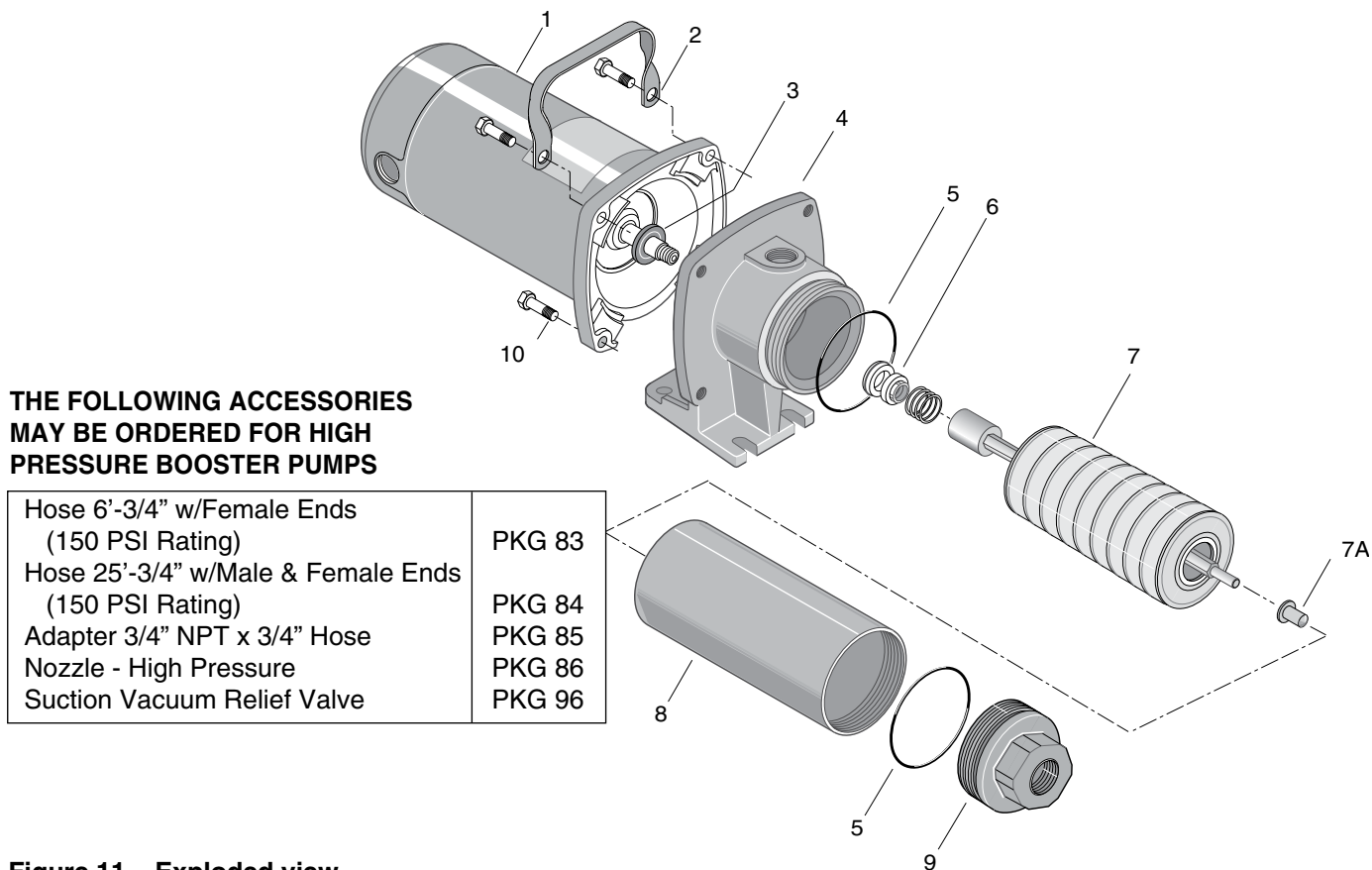
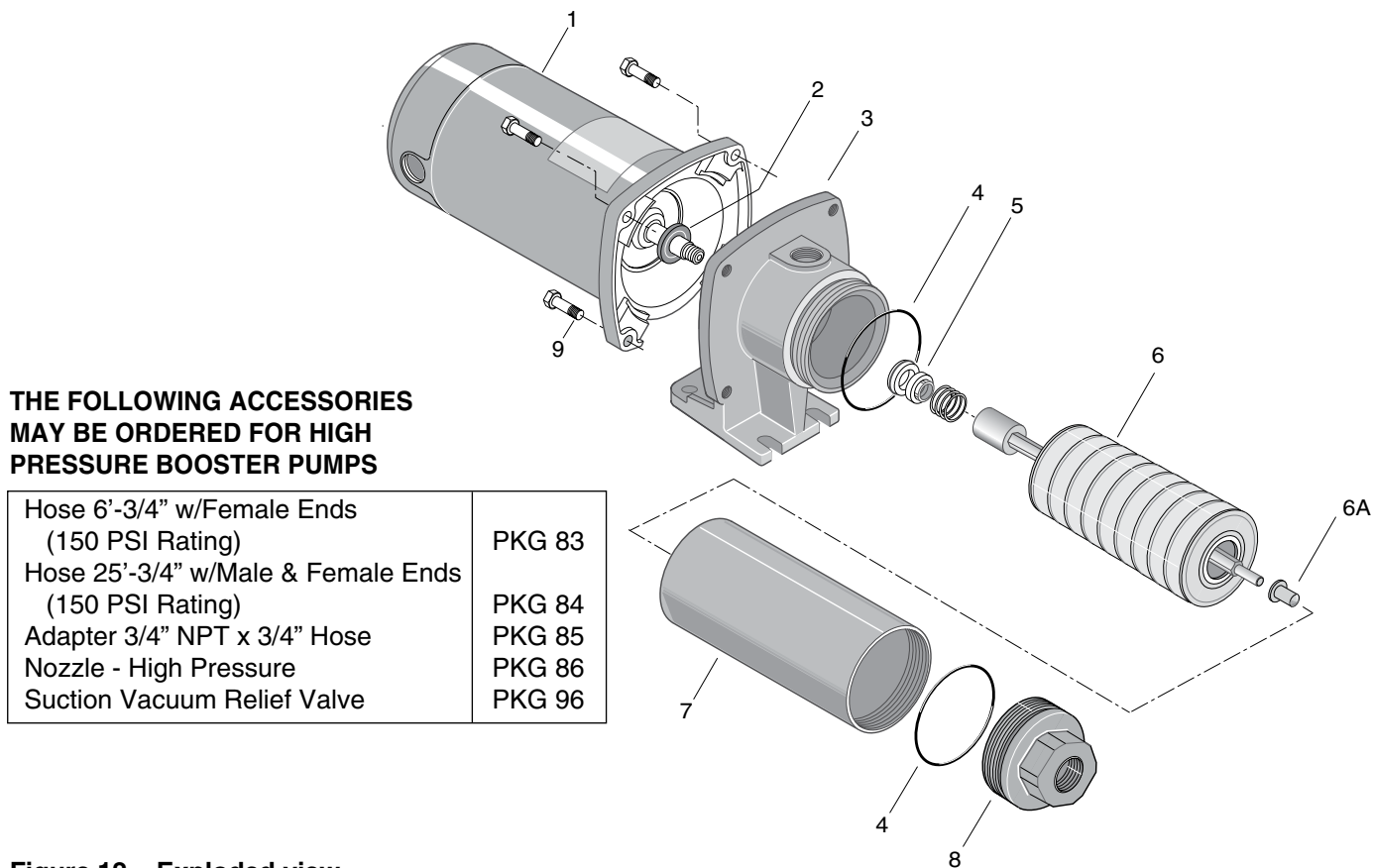

Figure 11 – Exploded view.

1206 0605 NCBSW/NB

## REPAIR PARTS LIST

Key No.	Description	Qty.	HP20E-02 HP20E3-02 1 HP	HP20F-02 HP20F3-02 1-1/2 HP	HP20G-02 HP20G3-02 2 HP	HP20H-01 HP20H3-01 HP20HT-02 HP20H3T-02 3 HP
1	Motor - 115/230 Volt, 1 Phase	1	J218-601PKG	J218-883APKG	J218-628APKG	–
1	Motor - 230 Volt, 1 Phase	1	–	–	A100GSL	AE100HLL
1	Motor - 230/460 Volt, 3 Phase	1	AP100EH	AP100FH	AP100GH	AP100HL
1	Motor - 230 Volt, 1 Phase, TEFC	1	–	–	–	J218-1035
1	Motor - 208-230/460 Volt, 3 Phase, TEFC	1	–	–	–	J218-1036
2	Handle	1	C54-21	C54-21	C54-21	C54-21
3	Water Slinger	1	17351-0009	17351-0009	17351-0009	17351-0009
4	Pump Body	1	C2-85A	C2-85A	C2-85A	C2-85A
5	O-Ring	2	U9-430	U9-430	U9-430	U9-430
6	Shaft Seal Assembly	1	U109-118	U109-118	U109-118	U109-118
7	Pump Stack	1	P325-602R	P325-431R	P325-432R	P325-718R
7A	Nylatron Bearing (included with Key No. 9)	1	W31112	W31112	W31112	W31112
8	Pump Shell	1	P56-433SSL	P56-434SSL	P56-452SSL	P56-620SSL
9	Discharge Assembly	1	C152-3A	C152-3A	C152-3A	C152-3A
10	Capscrew - 3/8 x 16 x 1-1/2"	4	U30-982ZP	U30-982ZP	U30-982ZP	U30-982ZP



**THE FOLLOWING ACCESSORIES  
MAY BE ORDERED FOR HIGH  
PRESSURE BOOSTER PUMPS**

Hose 6'-3/4" w/Female Ends (150 PSI Rating)	PKG 83
Hose 25'-3/4" w/Male & Female Ends (150 PSI Rating)	PKG 84
Adapter 3/4" NPT x 3/4" Hose	PKG 85
Nozzle - High Pressure	PKG 86
Suction Vacuum Relief Valve	PKG 96

**Figure 12 – Exploded view.**

1206 0605 NHW/NB

**REPAIR PARTS LIST**

Key No.	Description	Qty.	HPS20E-01 HPS20E3-01 1HP	HPS20F-01 HPS20F3-01 1-1/2 HP	HPS20G-01 HPS20G3-01 2 HP	HPS20H-01 HPS20H3-0 HPS20HT-01 HPS20H3T-01 3 HP
1	Motor - 115/230 Volt, 1 Phase	1	J218-601PKG	J218-883APKG	J218-628APKG	–
1	Motor - 230 Volt, 1 Phase	1	–	–	A100GSL	AE100HLL
1	Motor - 230/460 Volt, 3 Phase	1	AP100EL2	AP100FH	AP100GH	AP100HL
1	Motor - 230 Volt, 1 Phase, TEFC	1	–	–	–	J218-1035
1	Motor - 208-230/460 Volt, 3 Phase, TEFC	1	–	–	–	J218-1036
2	Water Slinger	1	17351-0009	17351-0009	17351-0009	17351-0009
3	Pump Body	1	C2-86SSA	C2-86SSA	C2-86SSA	C2-86SSA
4	O-Ring	2	U9-430	U9-430	U9-430	U9-430
5	Shaft Seal Assembly	1	U109-118	U109-118	U109-118	U109-118
6	Pump Stack	1	P325-440R	P325-431R	P325-432R	P325-718R
6A	Nylatron Bearing (included with Key No. 8)	1	W31112	W31112	W31112	W31112
7	Pump Shell	1	P56-470SSL	P56-434SSL	P56-452SSL	P56-620SSL
8	Discharge Assembly	1	C152-4A	C152-4A	C152-4A	C152-4A
9	Capscrew 3/8 x 16 x 1-1/2"	4	S25983	S25983	S25983	S25983

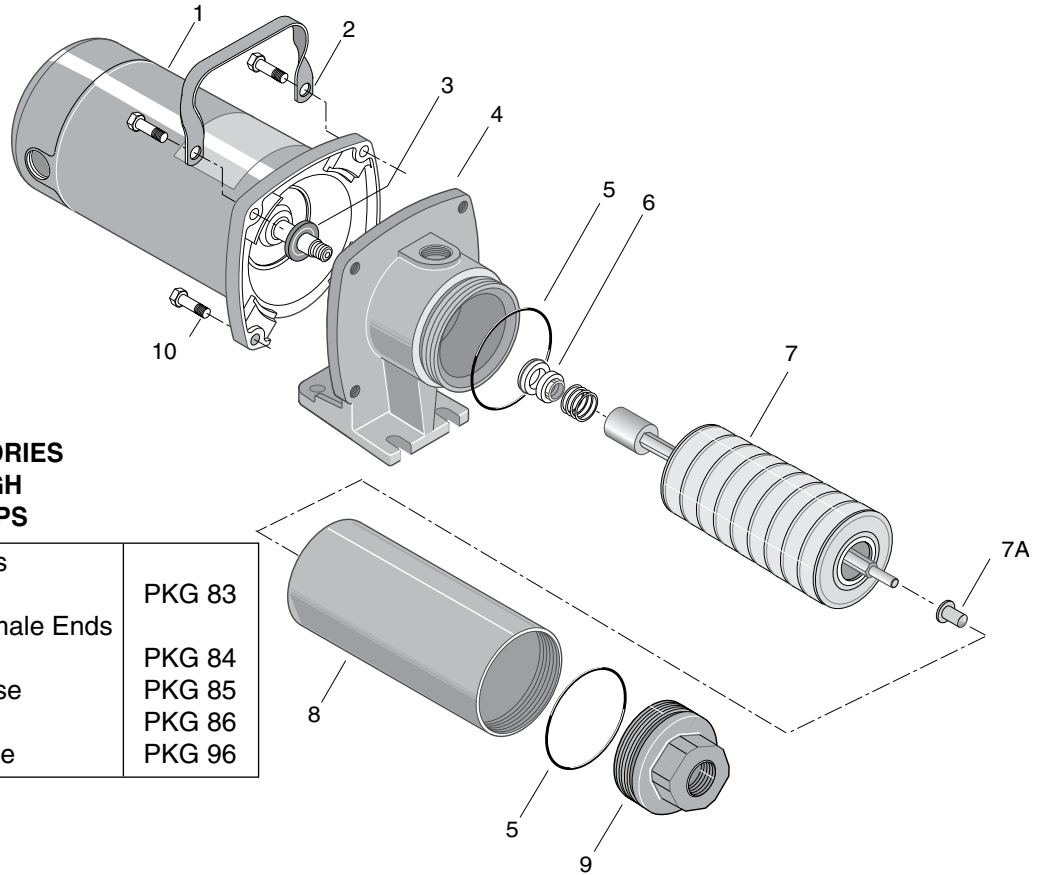

**THE FOLLOWING ACCESSORIES  
MAY BE ORDERED FOR HIGH  
PRESSURE BOOSTER PUMPS**

Hose 6'-3/4" w/Female Ends (150 PSI Rating)	PKG 83
Hose 25'-3/4" w/Male & Female Ends (150 PSI Rating)	PKG 84
Adapter 3/4" NPT x 3/4" Hose	PKG 85
Nozzle - High Pressure	PKG 86
Suction Vacuum Relief Valve	PKG 96

**Figure 13 – Exploded view.**

1206 0605 NCBSW/NB

**REPAIR PARTS LIST**

Key No.	Description	Qty.	HP30E-02 HP30E3-02 HP30ET-02 HP30E3T-02 1 HP	HP30F-02 HP30F3-02 HP30FT-02 HP30F3T-02 1-1/2 HP	HP30G-02 HP30G3-02 HP30GT-02 HP30G3T-02 2 HP	HP30H-02 HP30H3-02 HP30HT-02 HP30H3T-02 3 HP
1	Motor - 115/230 Volt, 1 Phase	1	J218-601PKG	J218-883APKG	J218-628APKG	—
1	Motor - 230 Volt, 1 Phase	1	—	—	A100GSL	AE100HLL
1	Motor - 230/460 Volt, 3 Phase	1	AP100EH	AP100FH	AP100GH	AP100HL
1	Motor - 230 Volt, 1 Phase, TEFC	1	A100FL-T	AE100GL-T	AE100G5L-T	J218-1035
1	Motor - 208-230/460 Volt, 3 Phase, TEFC	1	AP100FL-T	AP100GL-T	AP100G5L-T	J218-1036
2	Handle	1	C54-21	C54-21	C54-21	C54-21
3	Water Slinger	1	17351-0009	17351-0009	17351-0009	17351-0009
4	Pump Body	1	C2-85B	C2-85B	C2-85B	C2-85B
5	O-Ring	2	U9-430	U9-430	U9-430	U9-430
6	Shaft Seal Assembly	1	U109-118	U109-118	U109-118	U109-118
7	Pump Stack	1	P325-719R	P325-720R	P325-721R	P325-722
7A	Nylatron Bearing (included with Key No. 9)	1	W31112	W31112	W31112	W31112
8	Pump Shell	1	P56-621SSL	P56-622SSL	P56-434SSL	P56-615SSL
9	Discharge Assembly	1	C152-3B	C152-3B	C152-3B	C152-3B
10	Capscrew - 3/8 x 16 x 1-1/2"	4	U30-982ZP	U30-982ZP	U30-982ZP	U30-982ZP

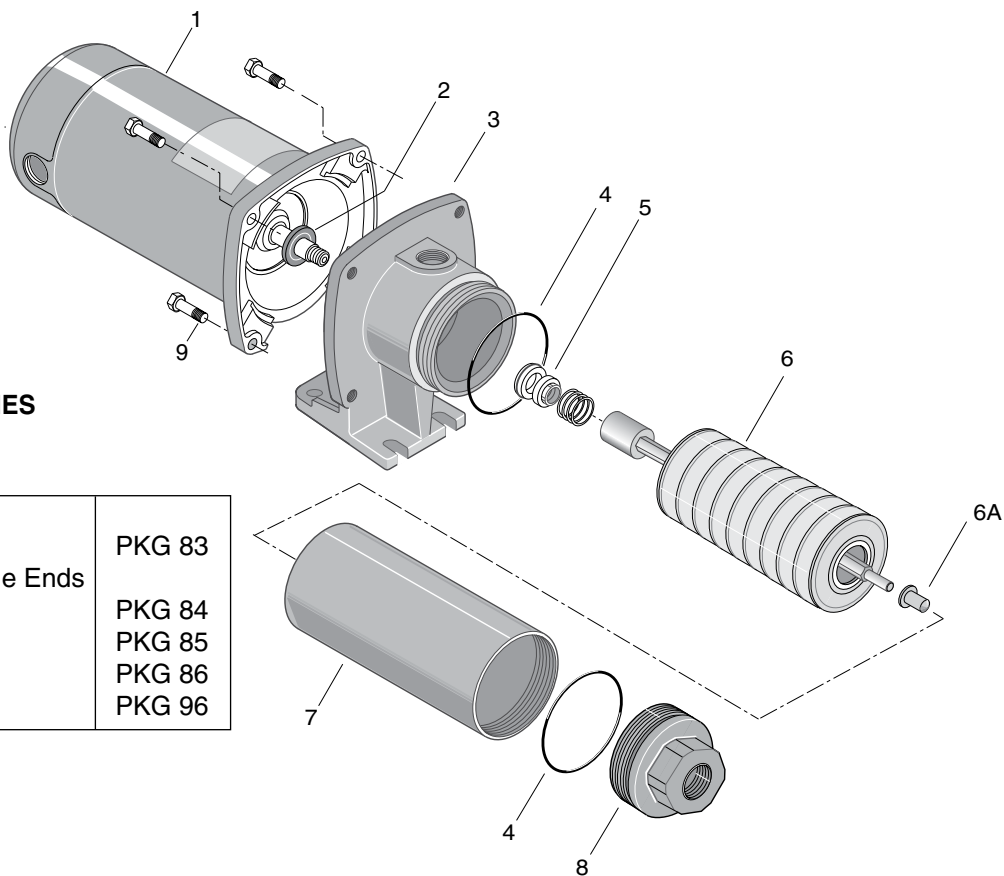

**THE FOLLOWING ACCESSORIES  
MAY BE ORDERED FOR HIGH  
PRESSURE BOOSTER PUMPS**

Hose 6'-3/4" w/Female Ends (150 PSI Rating)	PKG 83
Hose 25'-3/4" w/Male & Female Ends (150 PSI Rating)	PKG 84
Adapter 3/4" NPT x 3/4" Hose	PKG 85
Nozzle - High Pressure	PKG 86
Suction Vacuum Relief Valve	PKG 96

**Figure 14 – Exploded view.**

1206 0605 NHW/NB

**REPAIR PARTS LIST**

Key No.	Description	Qty.	HPS30E-01 HPS30E3-0 HPS30ET-01 HPS30E3T-01 1HP	HPS30F-01 HPS30F3-01 HPS30FT-01 HPS30F3T-01 1-1/2 HP	HPS30G-01 HPS30G3-01 HPS30GT-01 HPS30G3T-01 2 HP	HPS30H-01 HPS30H3-01 HPS30HT-01 HPS30H3T-01 3 HP
1	Motor - 115/230 Volt, 1 Phase	1	J218-601PKG	J218-883APKG	J218-628APKG	-
1	Motor - 230 Volt, 1 Phase	1	-	-	A100GSL	AE100HLL
1	Motor - 230/460 Volt, 3 Phase	1	AP100EH	AP100FH	AP100GH	AP100H
1	Motor - 230 Volt, 1 Phase, TEFC	1	A100FL-T	AE100GL-T	AE100G5L-T	J218-1035
1	Motor - 208230/460 Volt, 3 Phase, TEFC	1	AP100FL-T	AP100GL-T	AP100G5L-T	J218-1036
2	Water Slinger	1	17351-0009	17351-0009	17351-0009	17351-0009
3	Pump Body	1	C2-86SSB	C2-86SSB	C2-86SSB	C2-86SSB
4	O-Ring	2	U9-430	U9-430	U9-430	U9-430
5	Shaft Seal Assembly	1	U109-118	U109-118	U109-118	U109-118
6	Pump Stack	1	P325-719R	P325-720R	P325-721R	P325-722R
6A	Nylatron Bearing (included with Key No. 9)	1	W31112	W31112	W31112	W31112
7	Pump Shell	1	P56-621SSL	P56-622SSL	P56-434SSL	P56-615SSL
8	Discharge Assembly	1	C152-4B	C152-4B	C152-4B	C152-4B
9	Capscrew 3/8 x 16 x 1-1/2"	4	S25983	S25983	S25983	S25983

## Limited Warranty

STA-RITE warrants to the original consumer purchaser ("Purchaser" or "You") of the products listed below, that they will be free from defects in material and workmanship for the Warranty Period shown below.

Product	Warranty Period
Water Systems Products — jet pumps, small centrifugal pumps, submersible pumps and related accessories	<i>whichever occurs first:</i> 12 months from date of original installation, or 18 months from date of manufacture
Pro-Source™ Composite Tanks	5 years from date of original installation
Pro-Source™ Steel Pressure Tanks	5 years from date of original installation
Pro-Source™ Epoxy-Lined Tanks	3 years from date of original installation
Sump/Sewage/Effluent Products	12 months from date of original installation, or 18 months from date of manufacture

Our warranty will not apply to any product that, in our sole judgement, has been subject to negligence, misapplication, improper installation, or improper maintenance. Without limiting the foregoing, operating a three phase motor with single phase power through a phase converter will void the warranty. Note also that three phase motors must be protected by three-leg, ambient compensated, extra-quick trip overload relays of the recommended size or the warranty is void.

Your only remedy, and STA-RITE's only duty, is that STA-RITE repair or replace defective products (at STA-RITE's choice). You must pay all labor and shipping charges associated with this warranty and must request warranty service through the installing dealer as soon as a problem is discovered. No request for service will be accepted if received after the Warranty Period has expired. This warranty is not transferable.

STA-RITE SHALL NOT BE LIABLE FOR ANY CONSEQUENTIAL, INCIDENTAL, OR CONTINGENT DAMAGES WHATSOEVER. THE FOREGOING WARRANTIES ARE EXCLUSIVE AND IN LIEU OF ALL OTHER EXPRESS AND IMPLIED WARRANTIES, INCLUDING BUT NOT LIMITED TO THE IMPLIED WARRANTIES OF MERCHANTABILITY AND FITNESS FOR A PARTICULAR PURPOSE. THE FOREGOING WARRANTIES SHALL NOT EXTEND BEYOND THE DURATION EXPRESSLY PROVIDED HEREIN. Some states do not allow the exclusion or limitation of incidental or consequential damages or limitations on the duration of an implied warranty, so the above limitations or exclusions may not apply to You. This warranty gives You specific legal rights and You may also have other rights which vary from state to state.

This Limited Warranty is effective June 1, 2011 and replaces all undated warranties and warranties dated before June 1, 2011.

### **STA-RITE INDUSTRIES**

**293 Wright Street • Delavan, WI U.S.A. 53115**

**Phone: 1-888-782-7483 • Fax: 1-800-426-9446 • Web Site: sta-rite.com**